

# Ren:

---

A Premium, Sustainable Fashion Doll Kit That Teaches Children How To Sew!



# Table of Contents

---

Research	Ideation	Final Product
Design Goal..... 3	2D and 3D Sketches..... 15	Ren.....31
Toy Companies and Sustainability..... 4	2D Sketches..... 16	Brand.....32
Toy and Sustainability..... 5	2D and 3D Face Sketches..... 17	Average User.....33
Toy and Sustainability Examples..... 6	Final Figure Direction..... 18	Kids Can Sew?.....34
Current Sustainable Products..... 7	Learning to Sew..... 19	Why Sustainable Toys?.....35
Wooden Doll Costs..... 8	Digital Connections.....20	Beginner Box.....36
Wooden Dolls Mechanics..... 9	Play Pattern Ideation.....21	All Supplies.....37
Testing String Jointing..... 10	Doll House Ideation.....22	Doll.....38
Plant Based Hair..... 11	String Jointing.....23	Doll Styling.....39
Fashion Doll Demographic..... 12	First Doll Pack.....24	String Jointing.....40
Doll Body Types..... 13	Attachment Options.....25	Sewing Box.....41
	CustomizableWorld.....26	Box Supplies.....42
	Storage Options.....27	Box DIY.....43
	CustomizableWorld.....28	Sewing Box.....44
	Sewing Kits.....29	Learning to Sew.....45
		Fashion Kits.....46
		Sewing Levels.....47
		Levels with Examples.....48
		Digital Instructions.....49

Create a sustainable fashion doll that teaches children to sew.

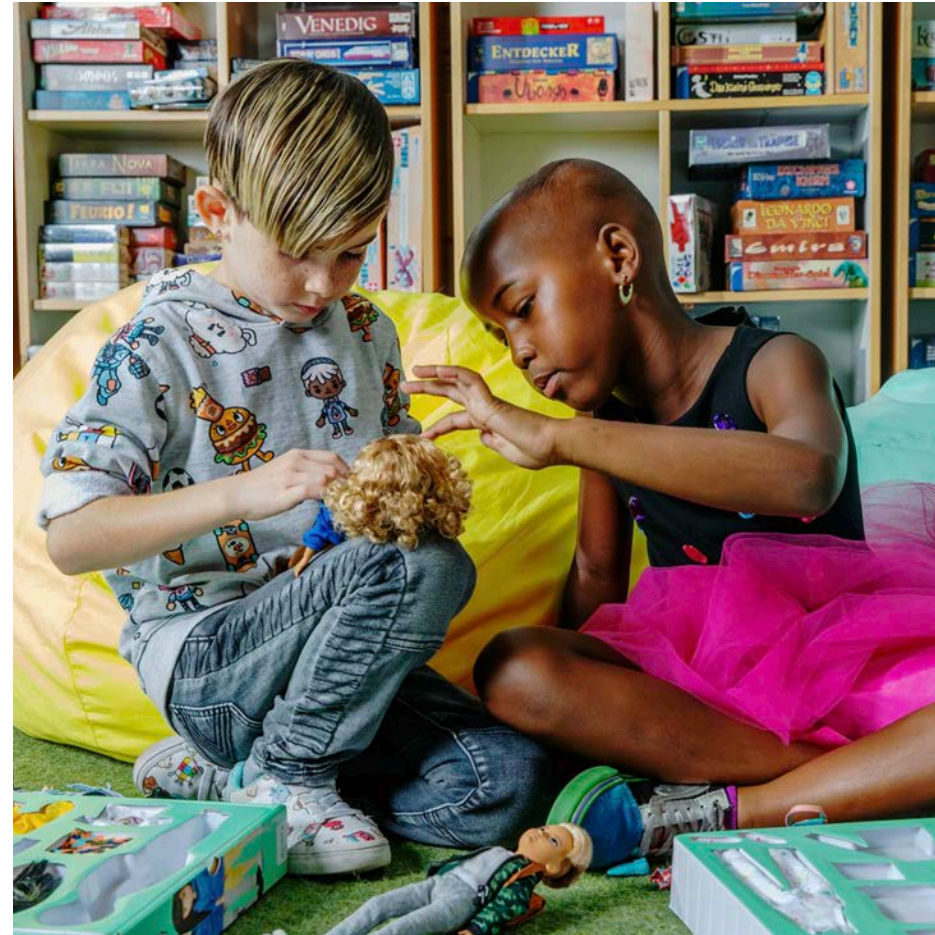

# Major Toy Companies and Sustainability Efforts



	Do they have a sustainability page?	Altering product to be eco friendly?	Eco friendly packaging?	Bioplastics and recycled plastics?	Disposal and take back services?	Non-plastic or plastic adjacement?
Mattel	✓	✓	✓	✓	✓	X
Hasbro	✓	✓	✓	✓	✓	✓
MGAE	X	X	X	X	X	X
LEGO	✓	✓	✓	✓	✓	X
Bandai Namco	✓	?	?	?	✓	?
Tomy	✓	X	✓	?	✓	X
Jakks Pacific	X	X	X	X	X	X
Funko	X	X	X	X	X	X
Spinmaster	✓	✓	✓	✓	✓	✓
Playmobil	✓	✓	✓	✓	X	X

## Toys are harmful to the environment in both production and disposal

**90%** of all toys are made of plastic

**80%** are landfilled, incinerated, or floating in the ocean

**6%** of all landfill plastic

**Plastic production emissions could overtake coal emissions by 2030.**



## Solutions to Explore

Regenerative Materials

Upcycled Waste Materials

Design For Repair

Slow Consumption

Plant Based Materials

# Current Sustainable Products

**Lego** no longer uses plastic packaging



**Hasbro** creates a Monopoly game with no plastic



**Playmobil** upcycles materials from old refrigerators



**Fisher Price** give option for plant based plastic toy vs new plastic



**Mattel** create dolls partially made with recycled plastic



**Hasbro** creates Mr. Potato Head with bioplastics

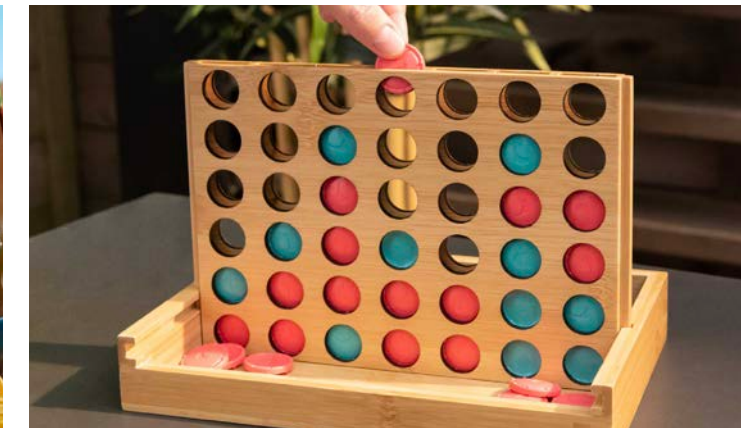

**Spinmaster** creates classic games using FSC certified bamboo



**Mattel** creates accessories from recycled plastic

# There are Low Cost Articulated Wooden Dolls

Price increases with complexity, details, and finishes



\$15.00

\$40.00

\$100.00

\$200.00

# How Do Wooden Manikins Work?

• 4.5" figure



• articulation with springs that hook around screws

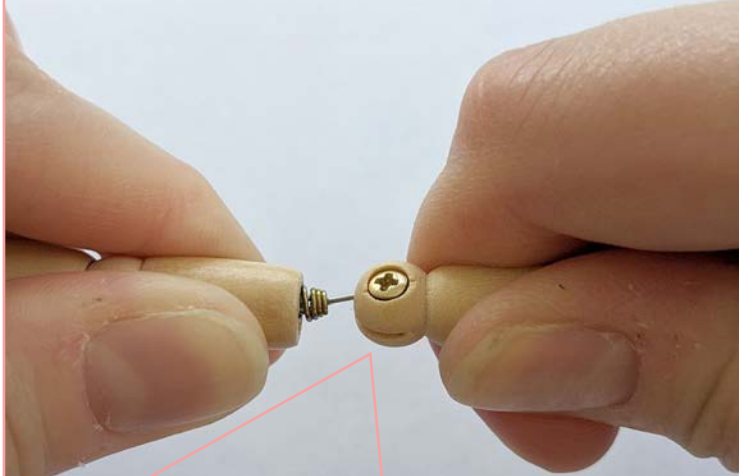

• hooks around screw or custom fixture

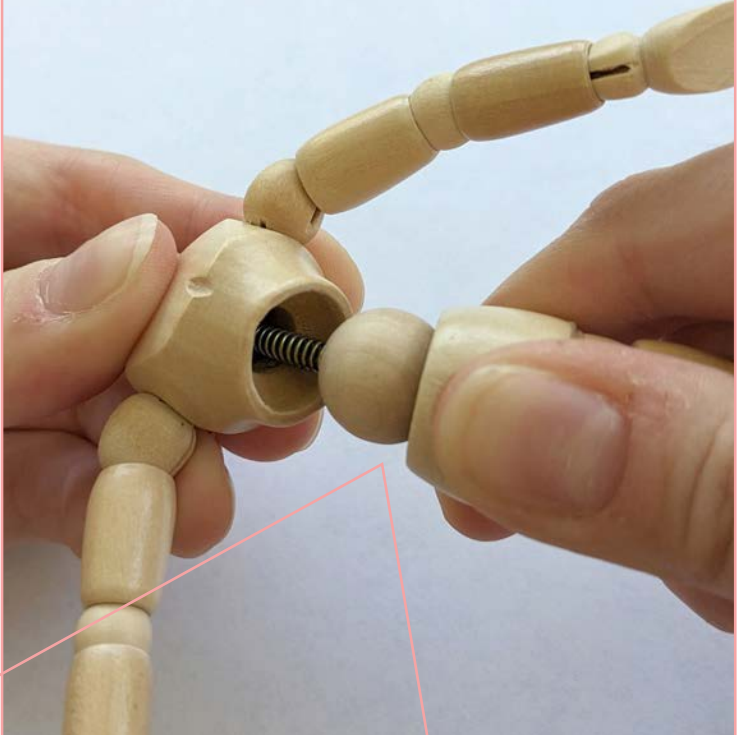

• half of parts spread out



• breakage on small parts





# Testing String Jointed Articulation

- replacing springs and hooks with an elastic string using a wire to thread string through parts



- entire arm can deform
- still using screw as anchor



- both arms are connected with one loop of elastic

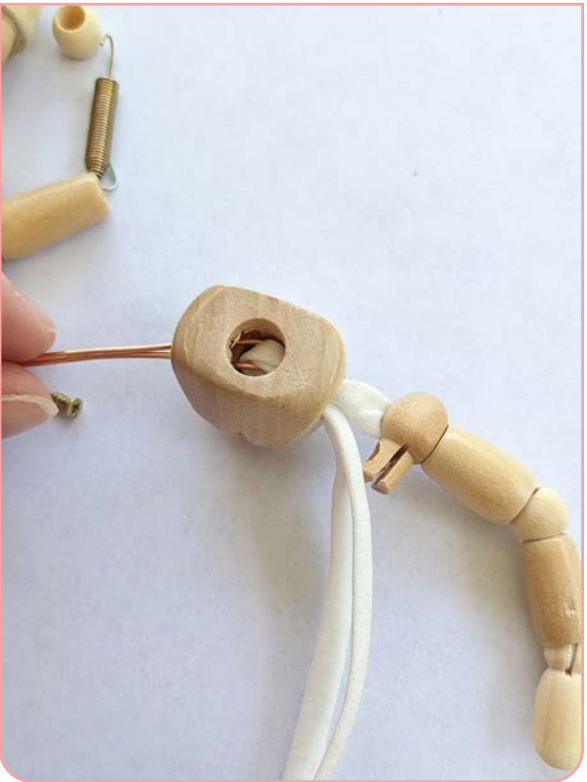

- string is hardly visible when in a static position



# Plant Based Hair Alternative

## REBUNDLE<sup>®</sup>

- Founder Ciara Imani May had experienced too many itchy scalps when wearing protective styles
- Decided to create new hair fibers for both comfort and sustainability
- more comfort, less waste
- biodegradable and vegan
- None of the ingredients used in braidbetter appear on California's Prop 65 list of banned chemicals
- Main Ingredients: Banana fiber, Reactive Dye, Aloe Barbadensis (Aloe Vera) Leaf Juice, Glycerin, Isododecane, Isopropyl Palmitate, Grapeseed Oil, Neopentyl Glycol Diheptanoate, Diheptyl Succinate, Capryloyl Glycerin, Sebacic Acid Copolymer
- Can be properly disposed of with yard waste!

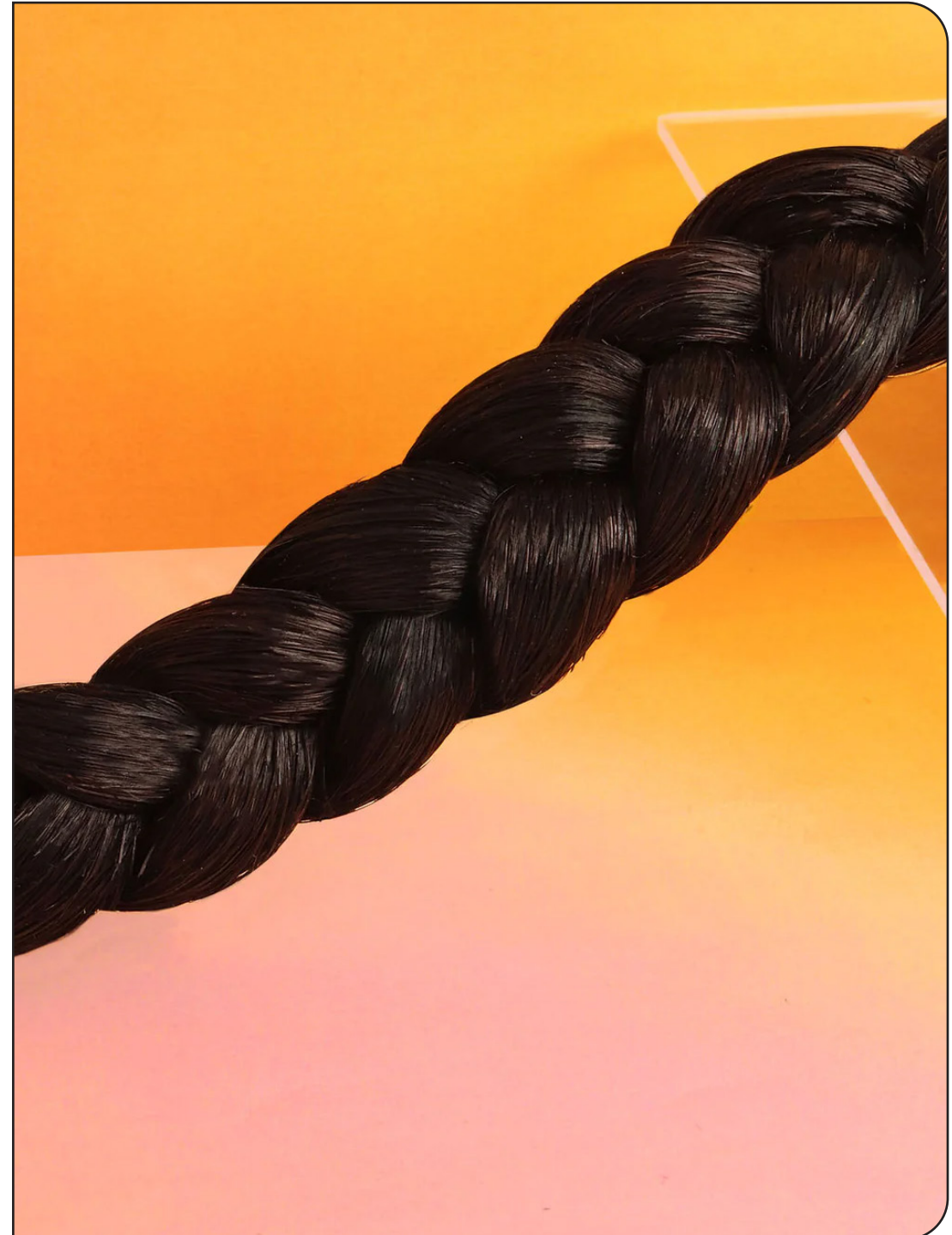

# Fashion Dolls For Older Girls

## Recapturing the 9-12 y/o use base:

- In the early 2000's...
- Mattel creates MyScene dolls to compete with Bratz
- Bratz were more appealing to young girls with edgier fashions
- Older girls are always a difficult demographic to sell dolls to
- With the advent of screens, kids are leaving dolls behind sooner

“We hear at Toy Fair every year from all the manufacturers that something is perfect for the 8-to-12-year-old girl,” said KB Toy’s Glazer. **“And there hasn’t been a lot of success.”**



MGA - Bratz



Mattel - MyScene

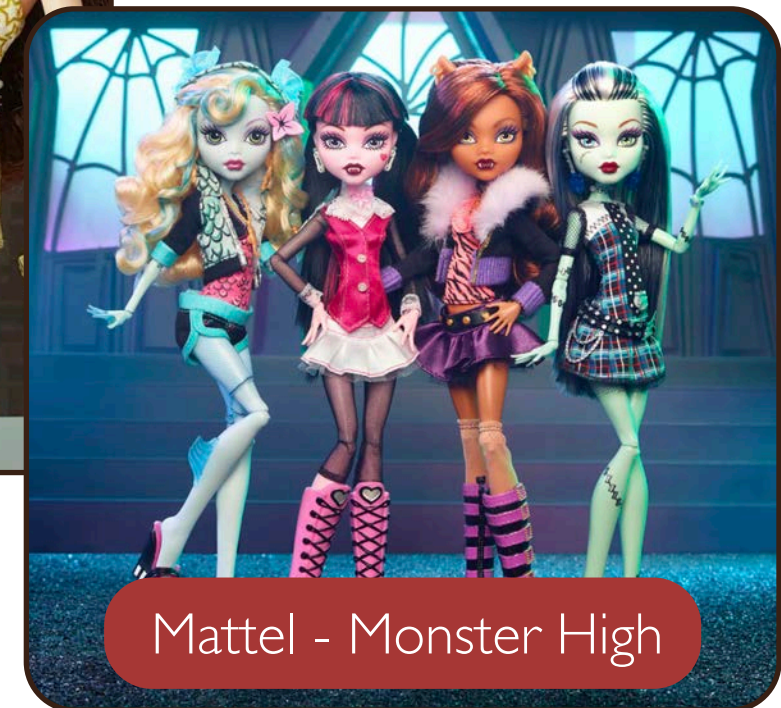

Mattel - Monster High

# Logistics of Multiple Doll Figures

## Tall, Curvy, Petite...

- In 2016, Mattel released 3 Barbies each with a unique shape
- 92% of girls 3-12 have owned a Barbie doll
- Now all Barbie outfits do not fit every Barbie, adding frustration to both kids and parents
- There are now two Barbie Shoe size, more incompatible parts
- Other girls toys are outperforming Barbie - like Lego Friends
- Previous General Manager of Barbie, Evelyn Mazzacco received hate mail and death threats over Barbie's body
- "A 2006 study published in the journal *Developmental Psychology*, found that girls exposed to Barbie at a young age expressed greater concern with being thin, compared with those exposed to other dolls." - Eliana Dockterman [3]
- "lost popularity among consumers over the past few years due to promoting a negative body image, perceived sexism, and lack of Barbie diversity" Forbes [9]
- Kids were typically choosing dolls based on matching hair color not based on matching body size



# 3D Printing Testing

Wood Filament has very little flex, breaks when fitting a foot into the shoe



3D Printed Wood



3D Printed Wood



Various 3D Prints - PLA and ABS



3D Printed Wood

**Ren:**

Ideation

---

# 2D and 3D Figure Explorations

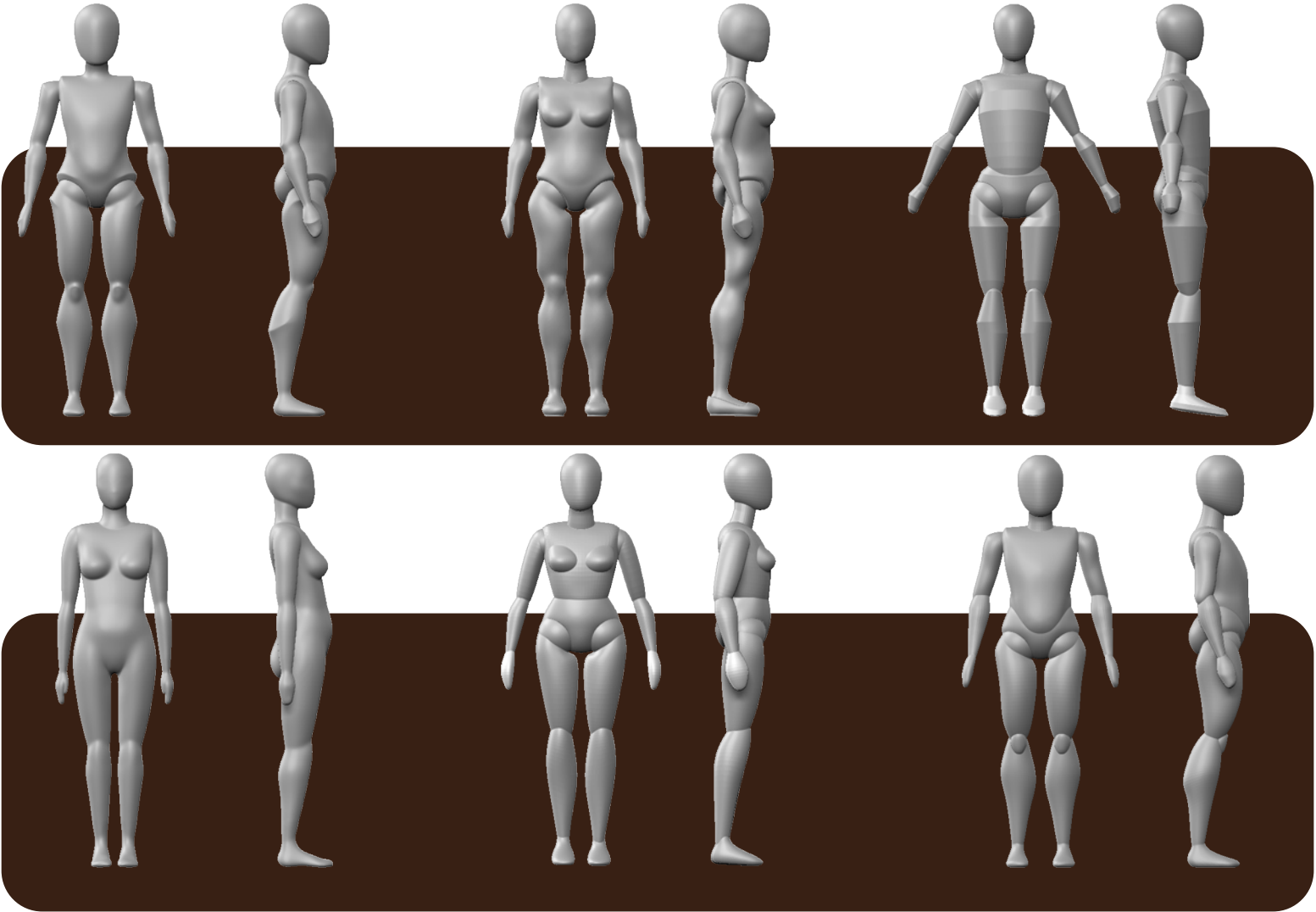
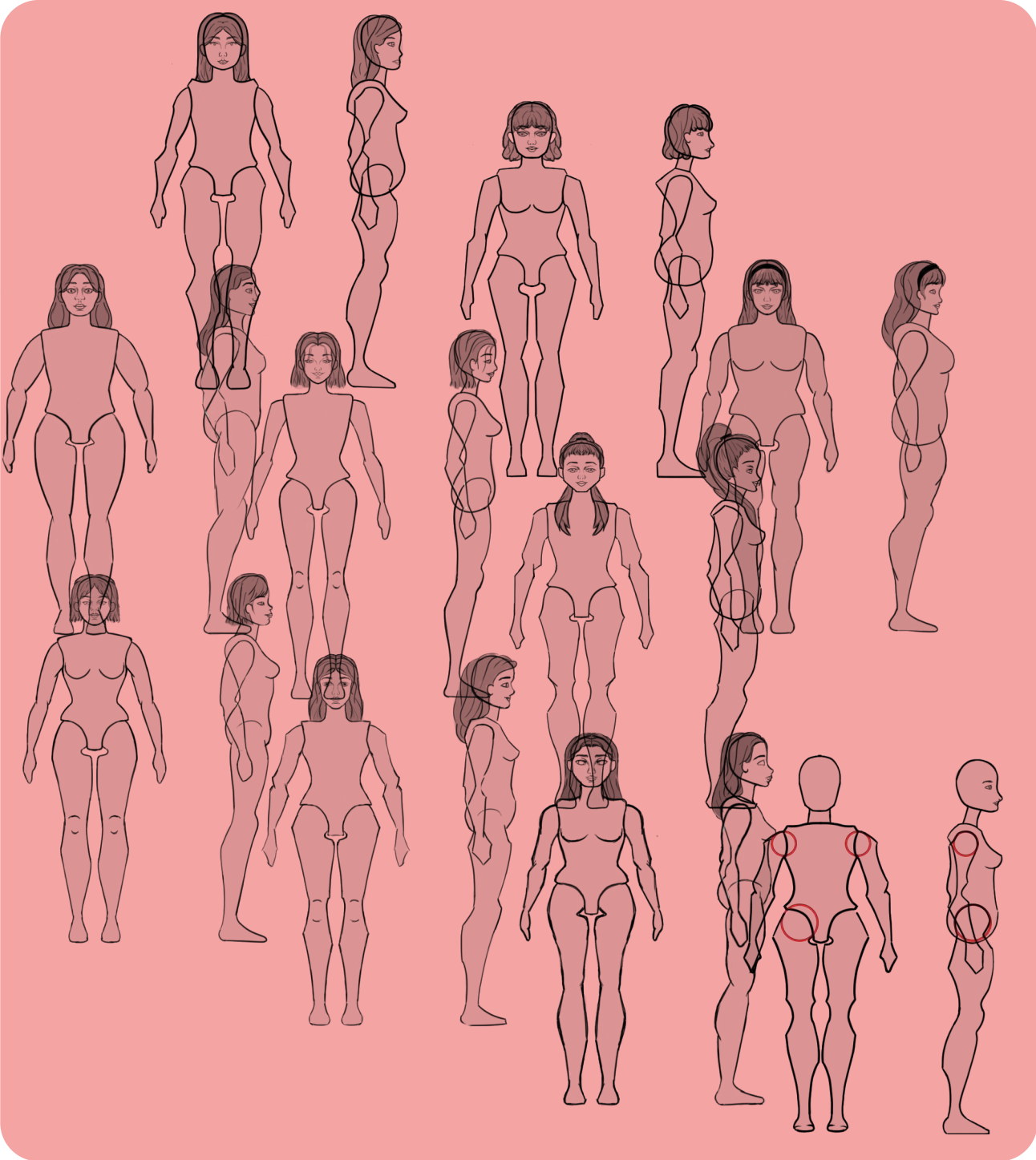

# 2D Figure Explorations

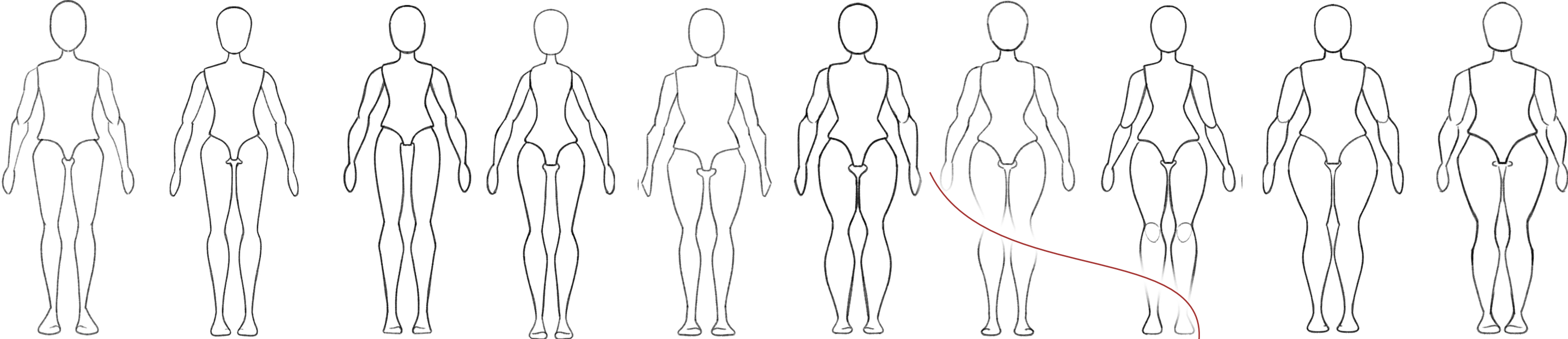

Focus on strong but not toned bodies

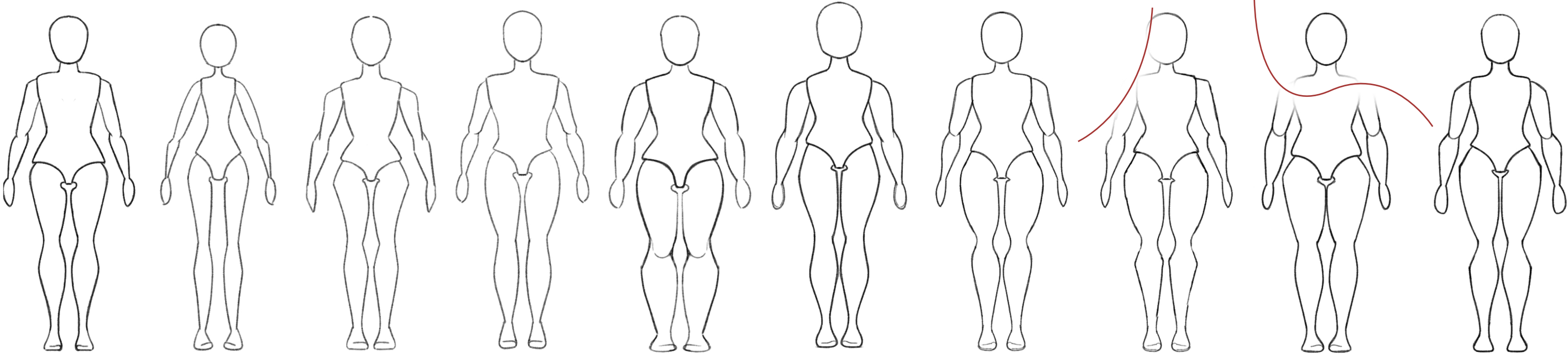



# 2D and 3D Face Explorations

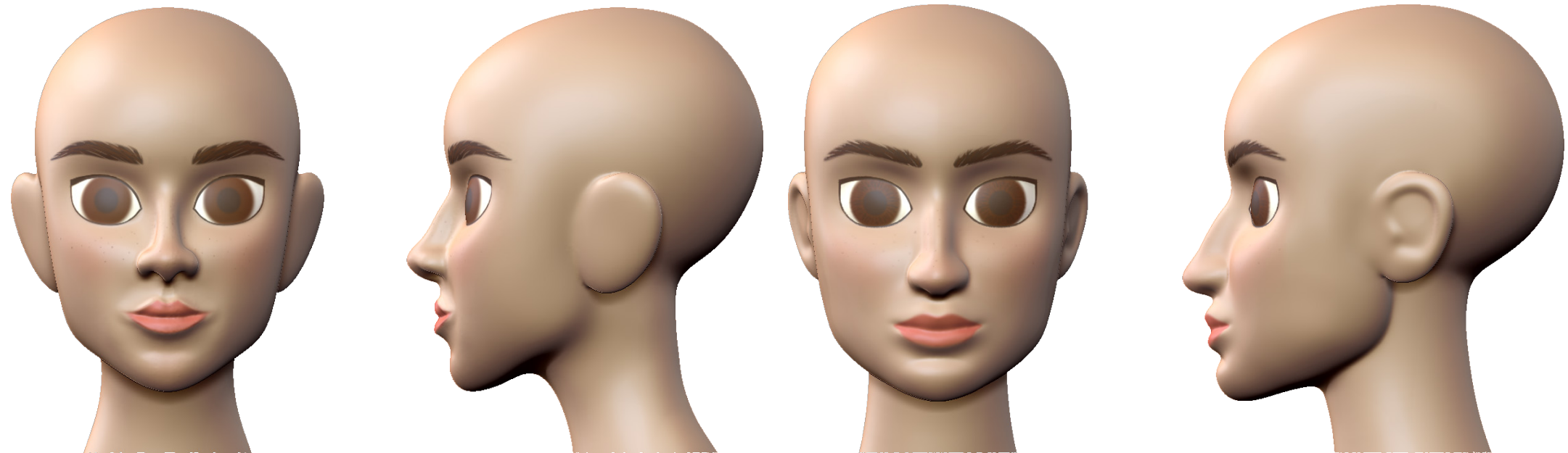
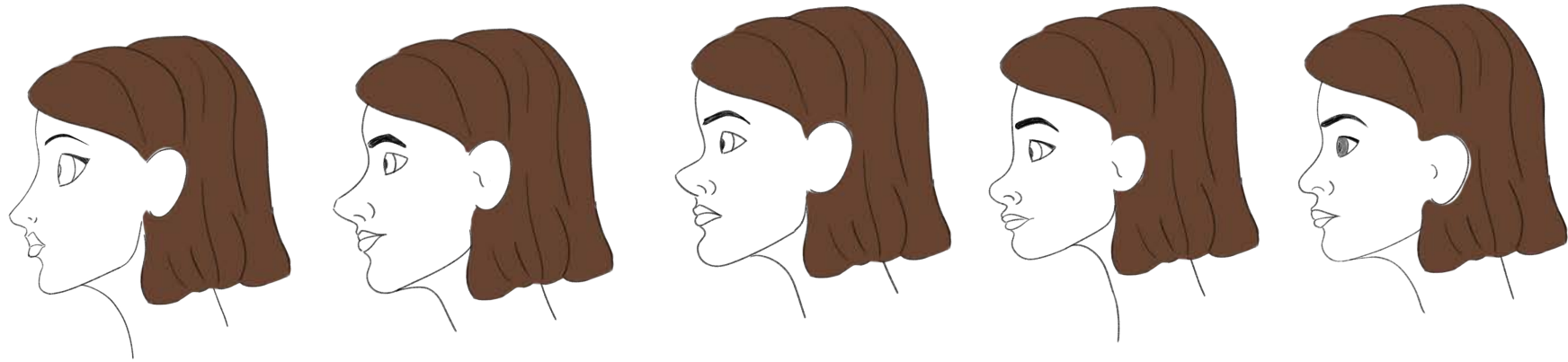
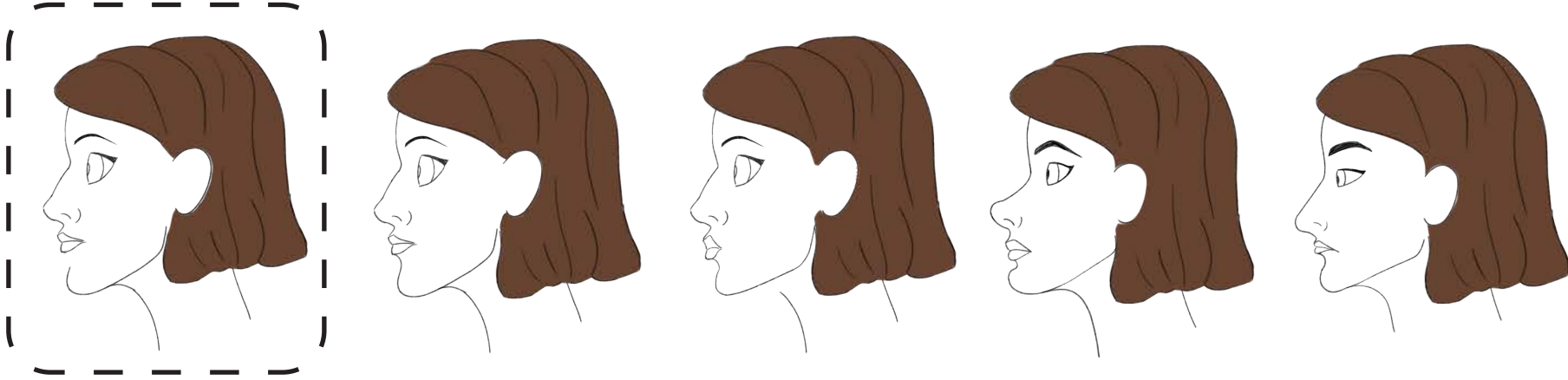

# Final Figure Direction

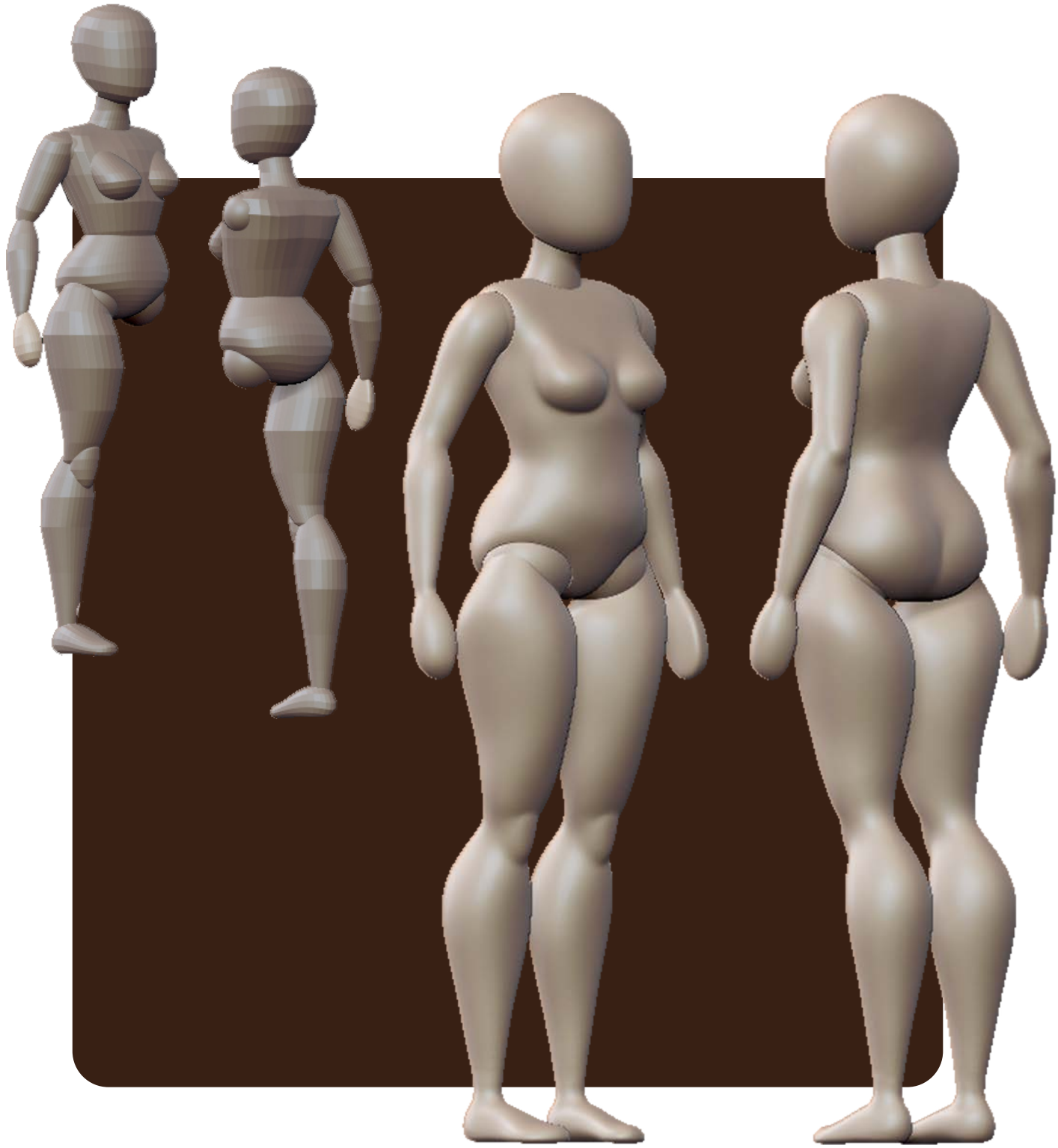
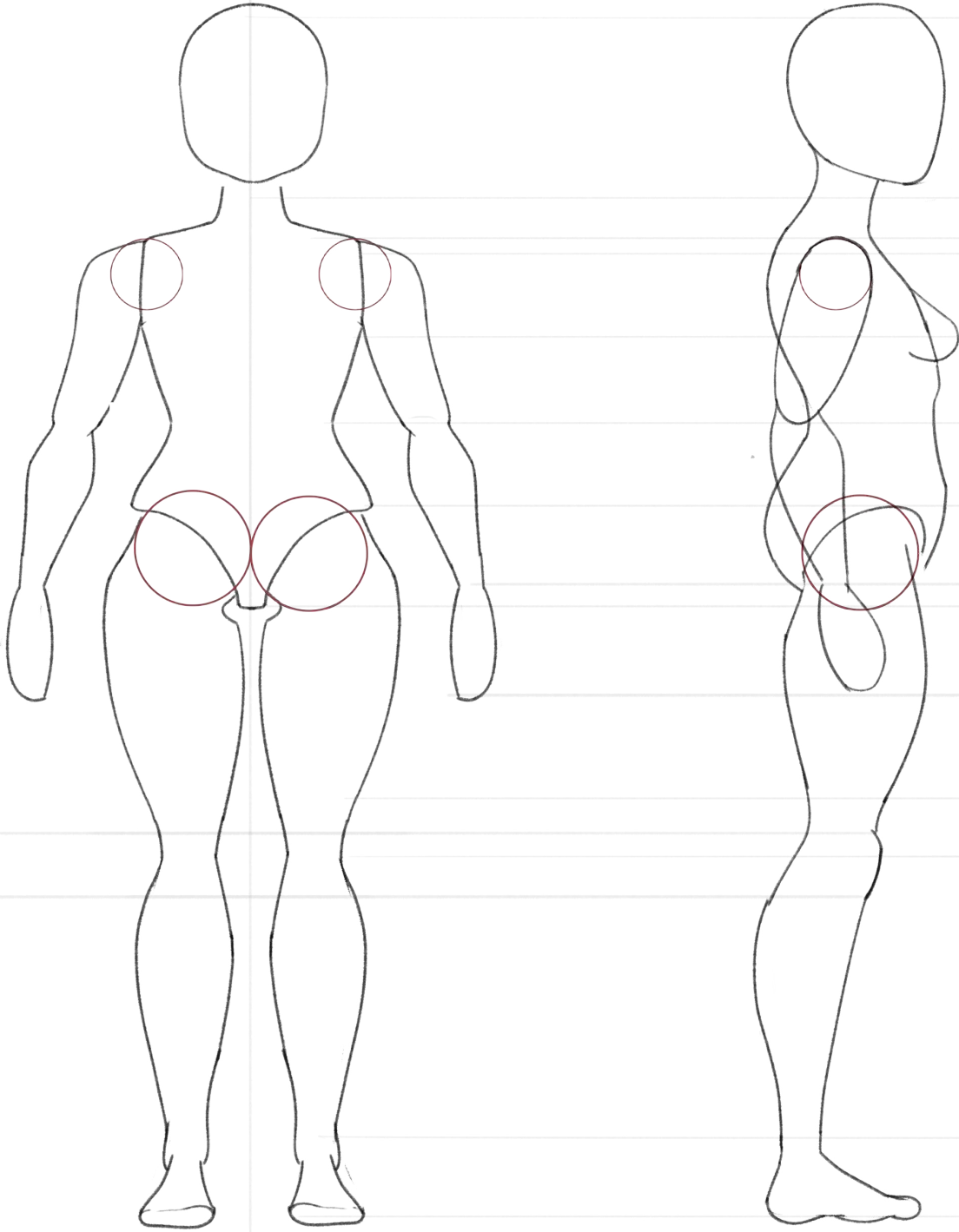

# Learning to Sew Assistance on Figure

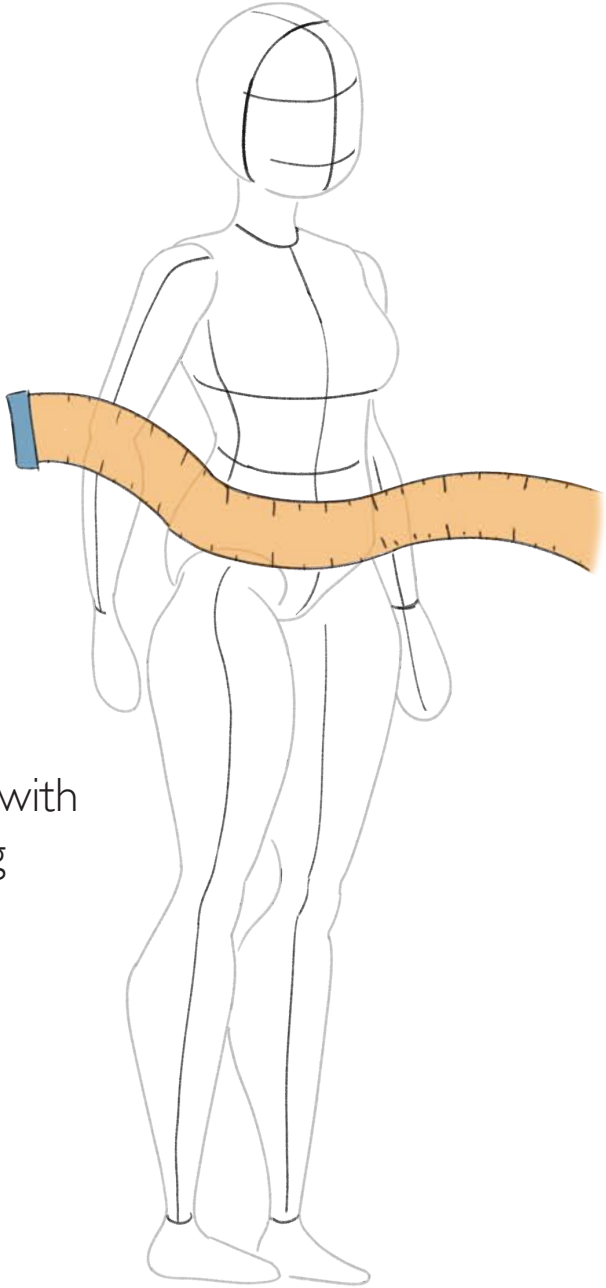

Lines to help with measuring

Book of flat patterns for standard styles

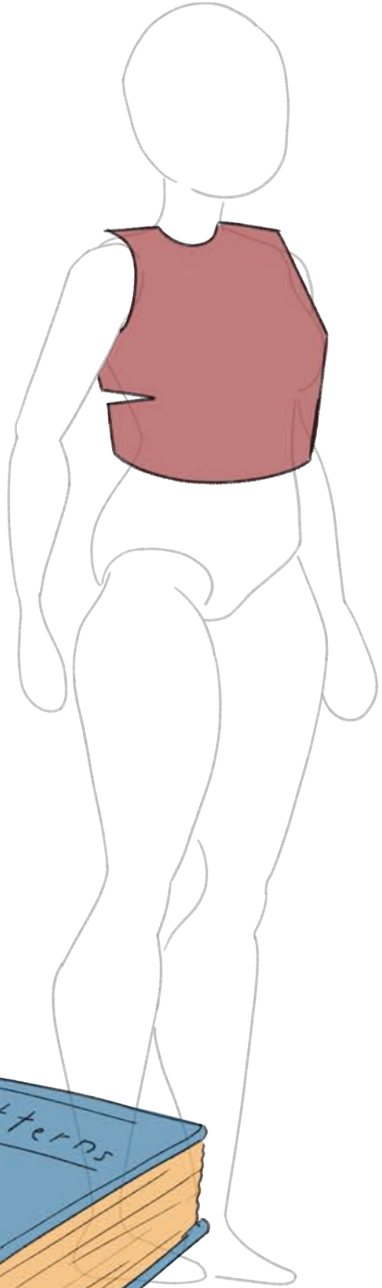
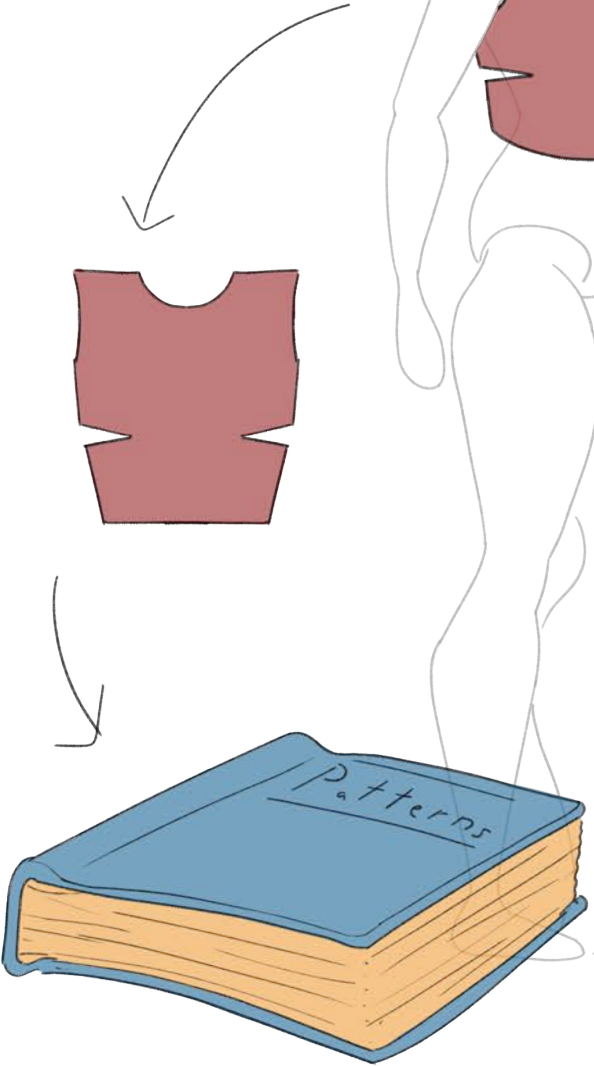

Easy draping on doll made of cork

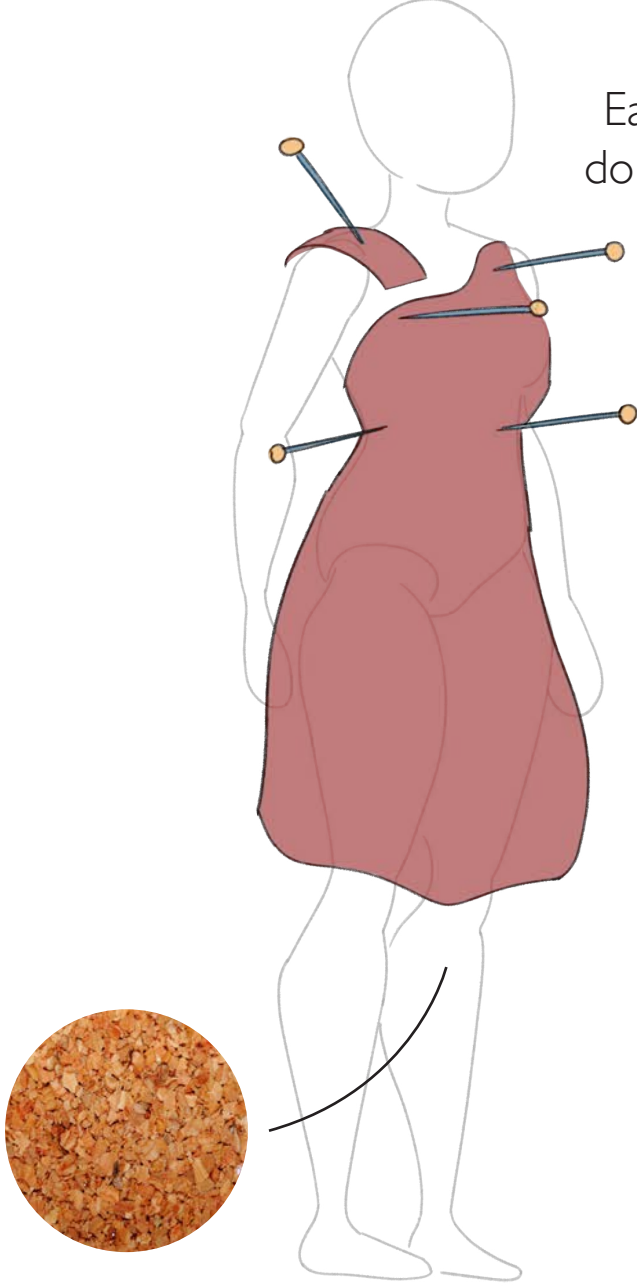

Design In Your  
Digital Workshop!



Sew Up Your  
Clothes!



Print Out  
Your Pattern!

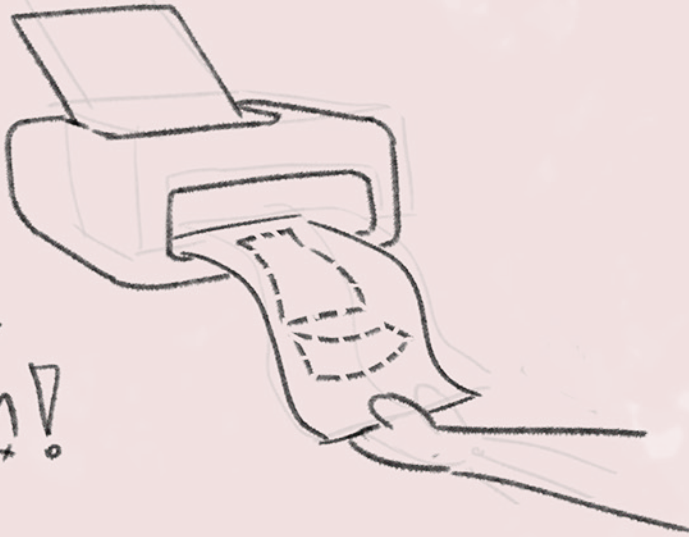

# DIY Play Pattern Ideation

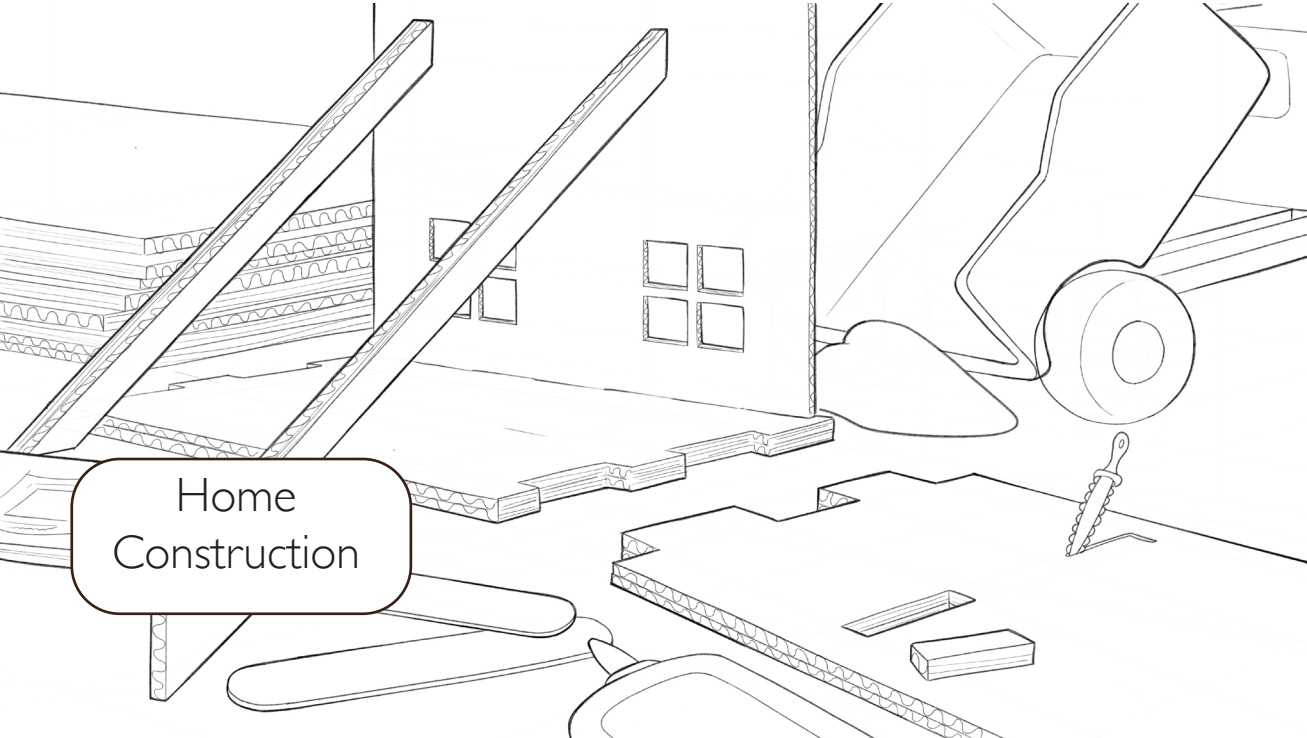
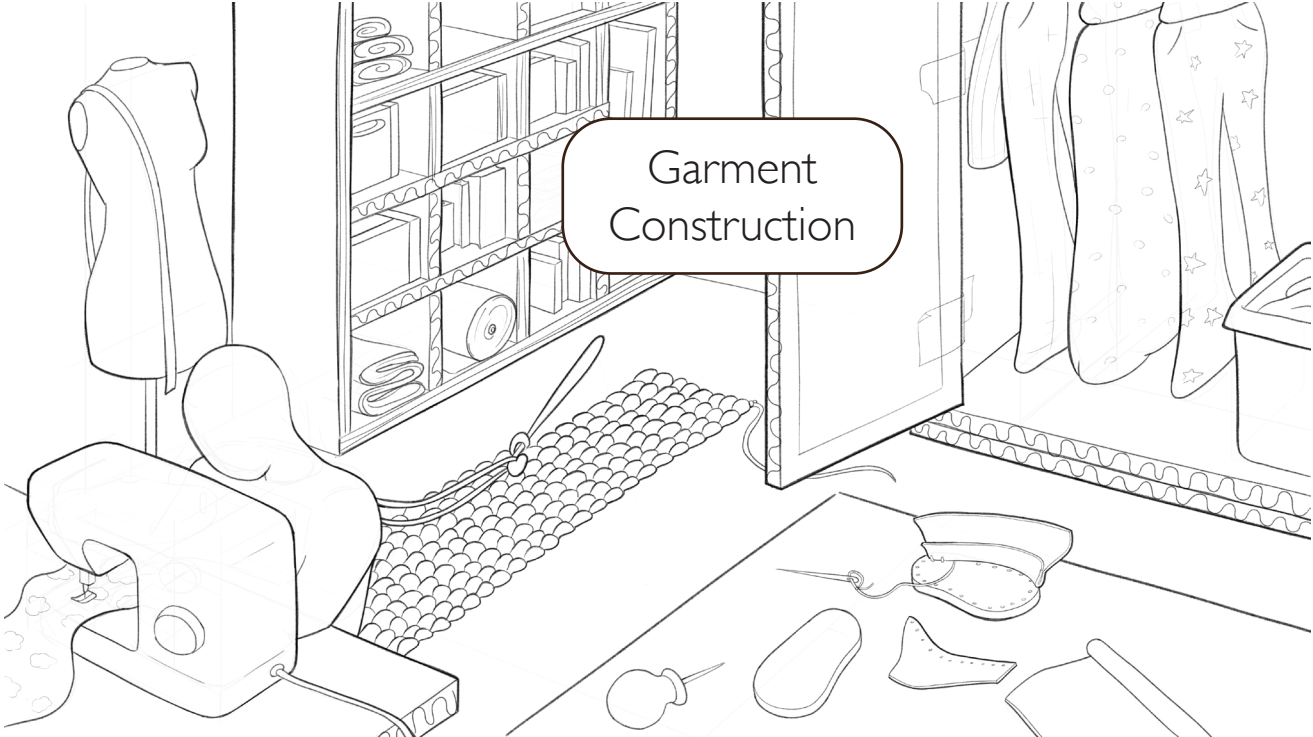

# Doll House Ideation

1

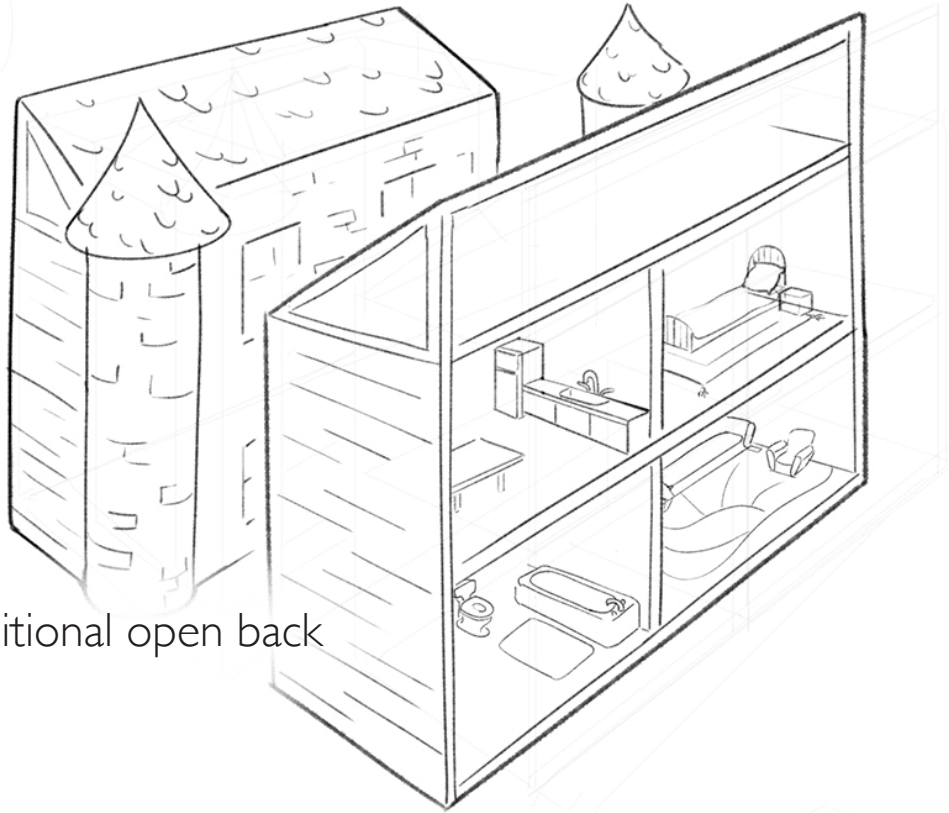

Traditional open back

3

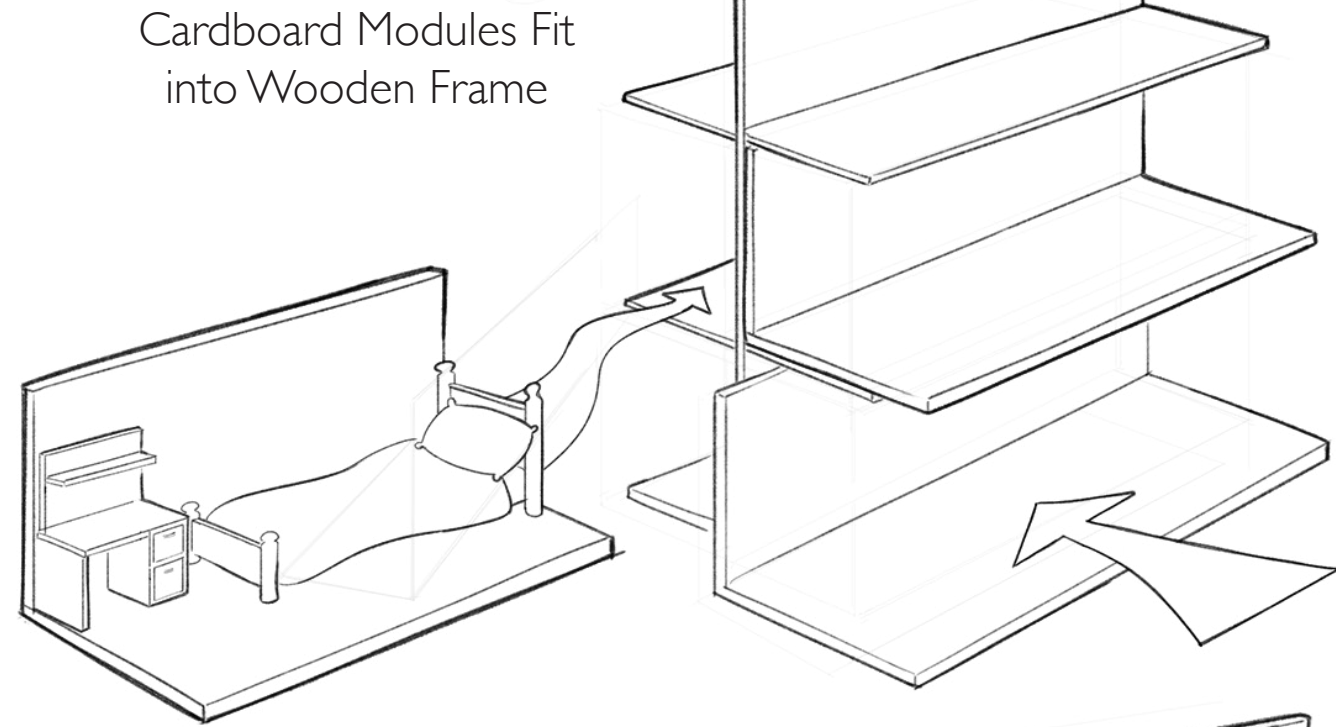

Cardboard Modules Fit into Wooden Frame

4

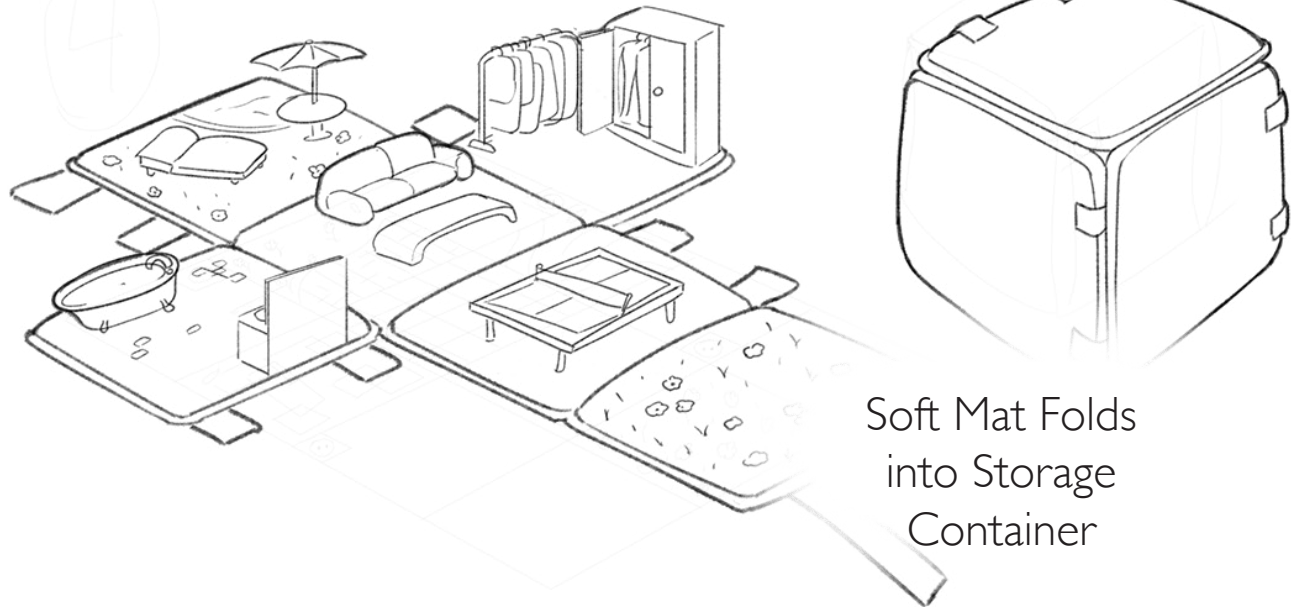

Soft Mat Folds into Storage Container

5

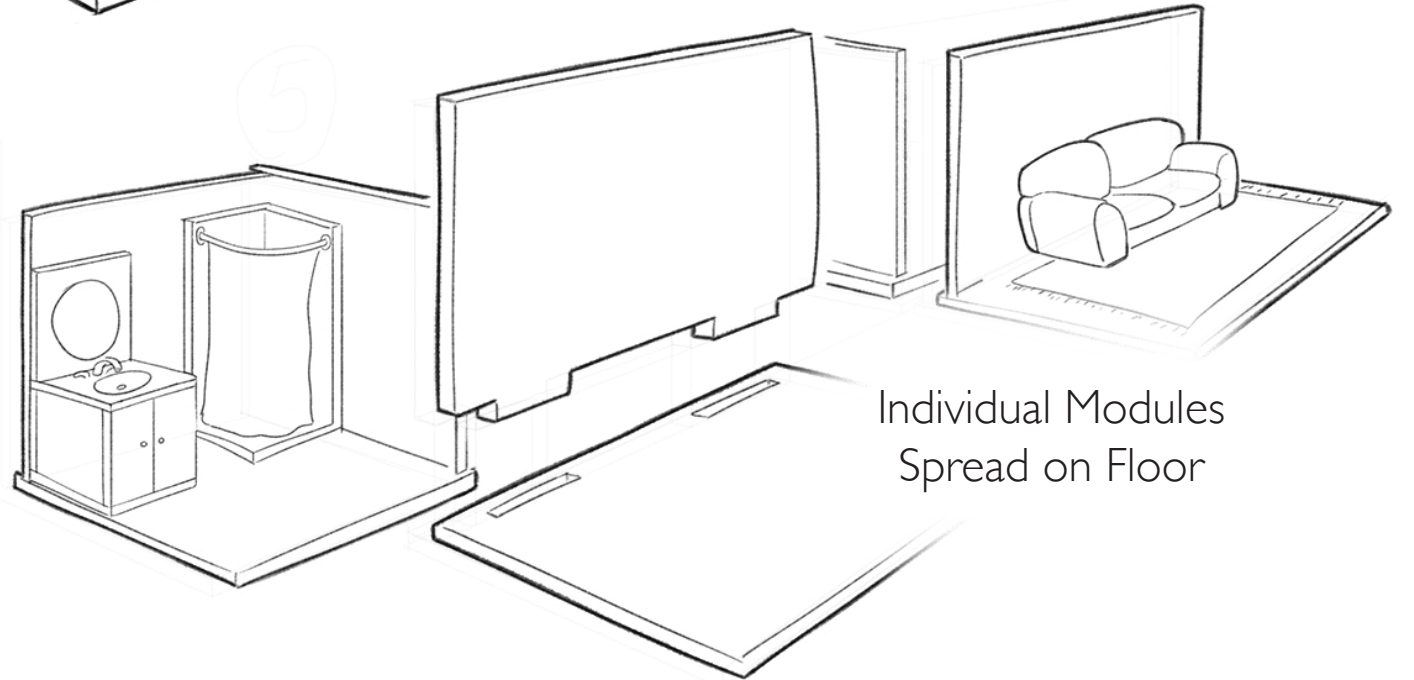

Individual Modules Spread on Floor

# String Jointing



CNC Milled Wood  
Prototyped in 3D Printed Wood

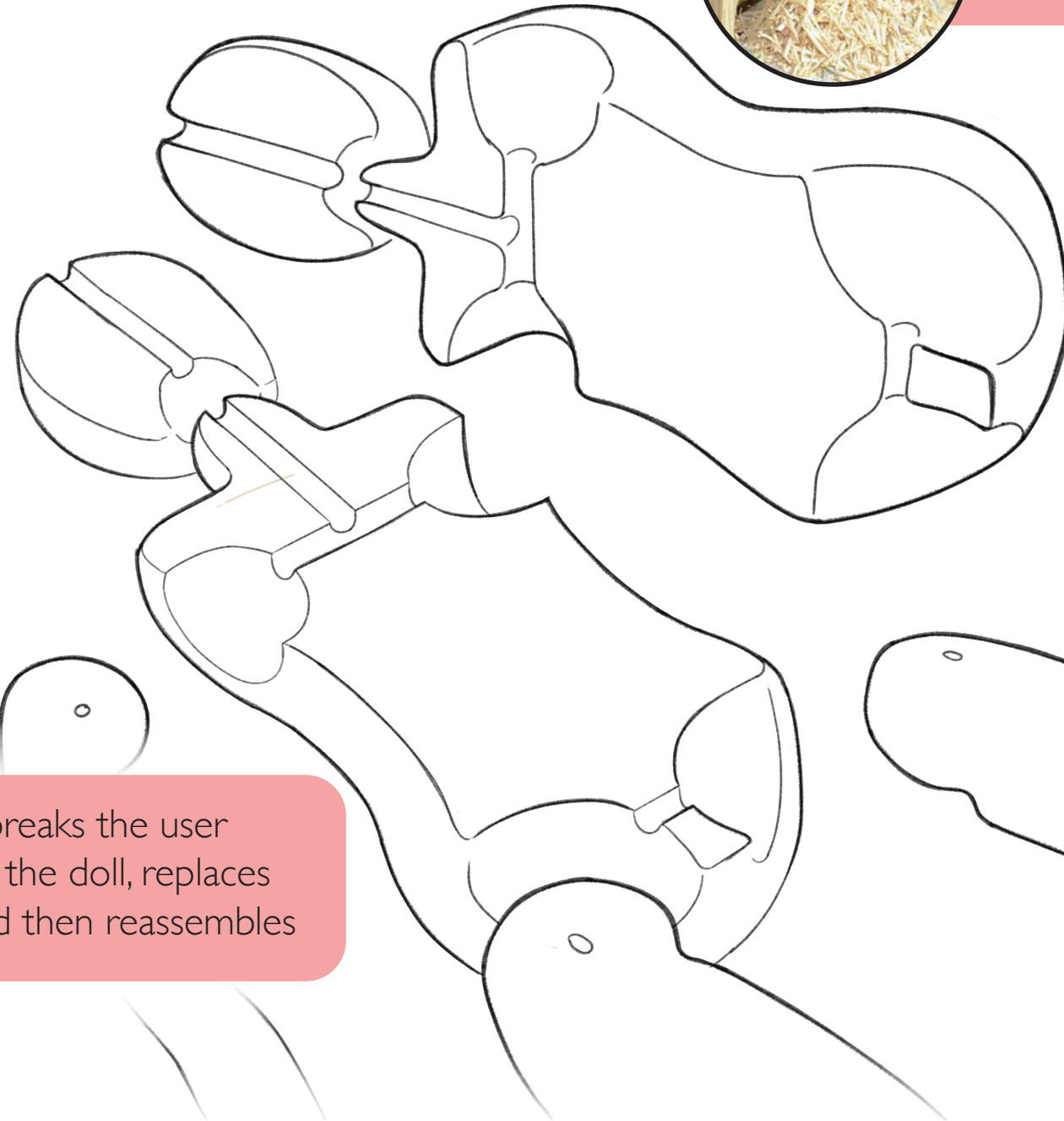

If the string breaks the user disassembles the doll, replaces the string and then reassembles

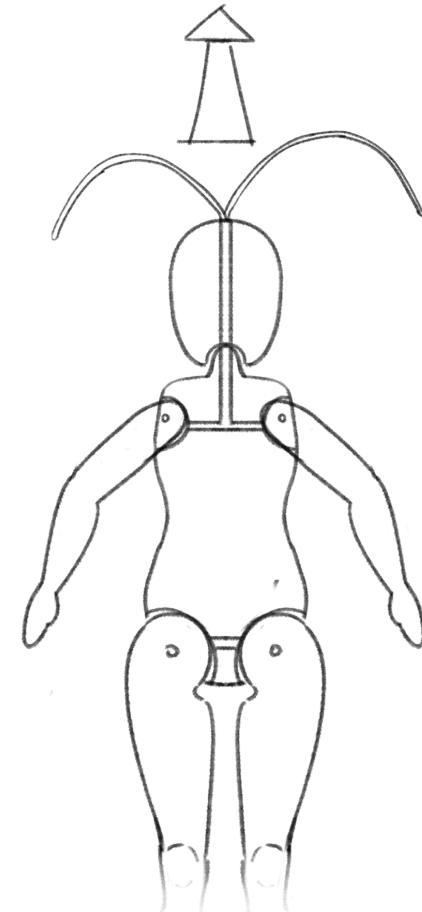
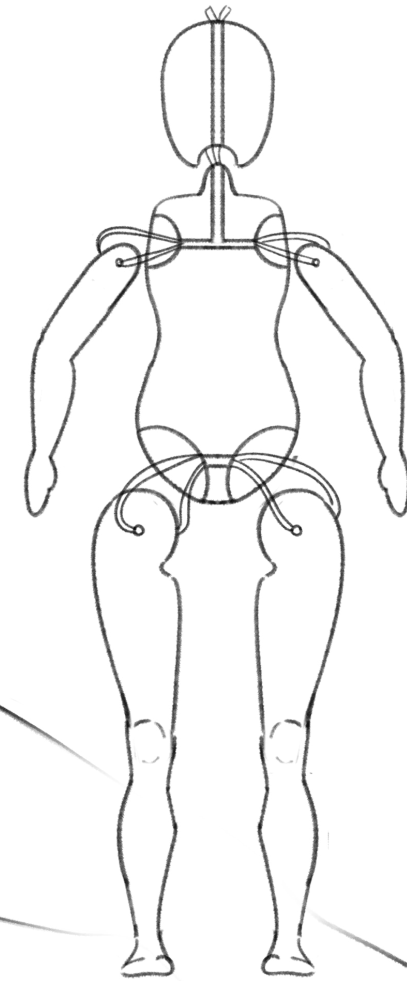

Elastic cord holds limbs together and allows for movement

# First Doll Pack

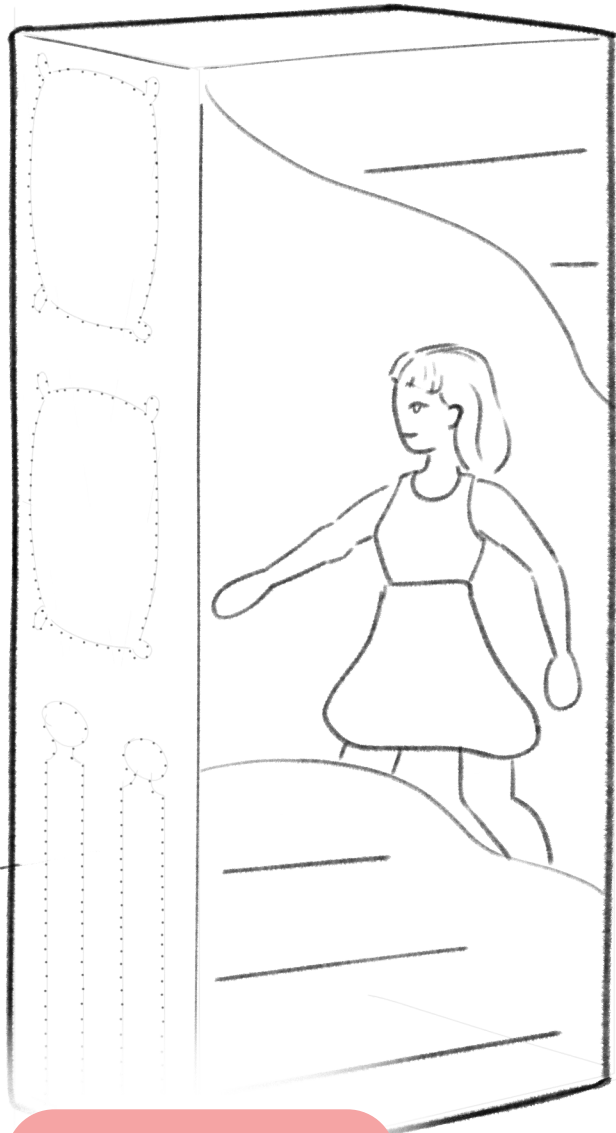

Perforated parts pop out



Package Transforms into a bed

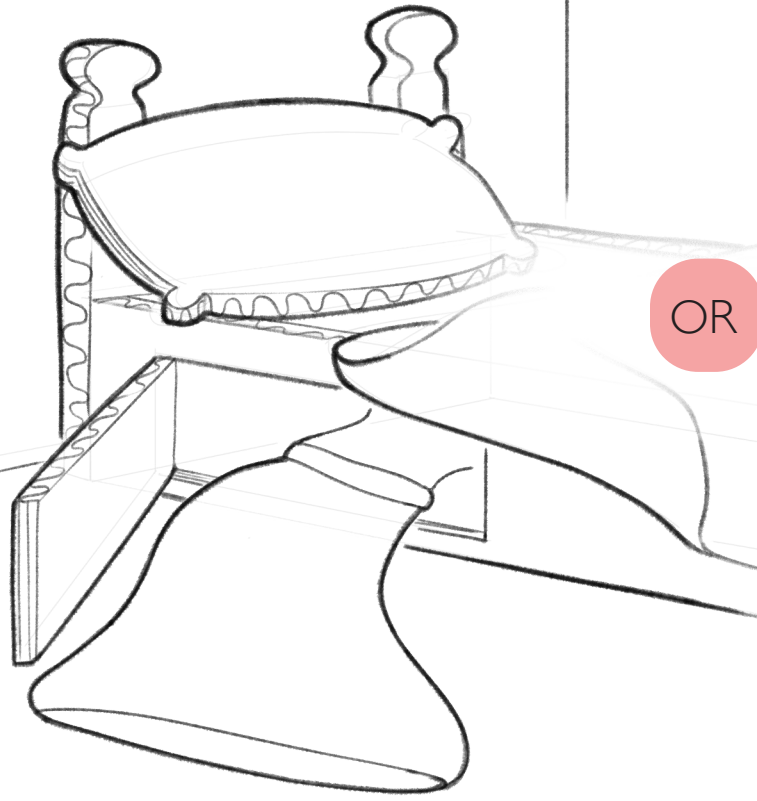

OR

Package Transforms into a Wardrobe

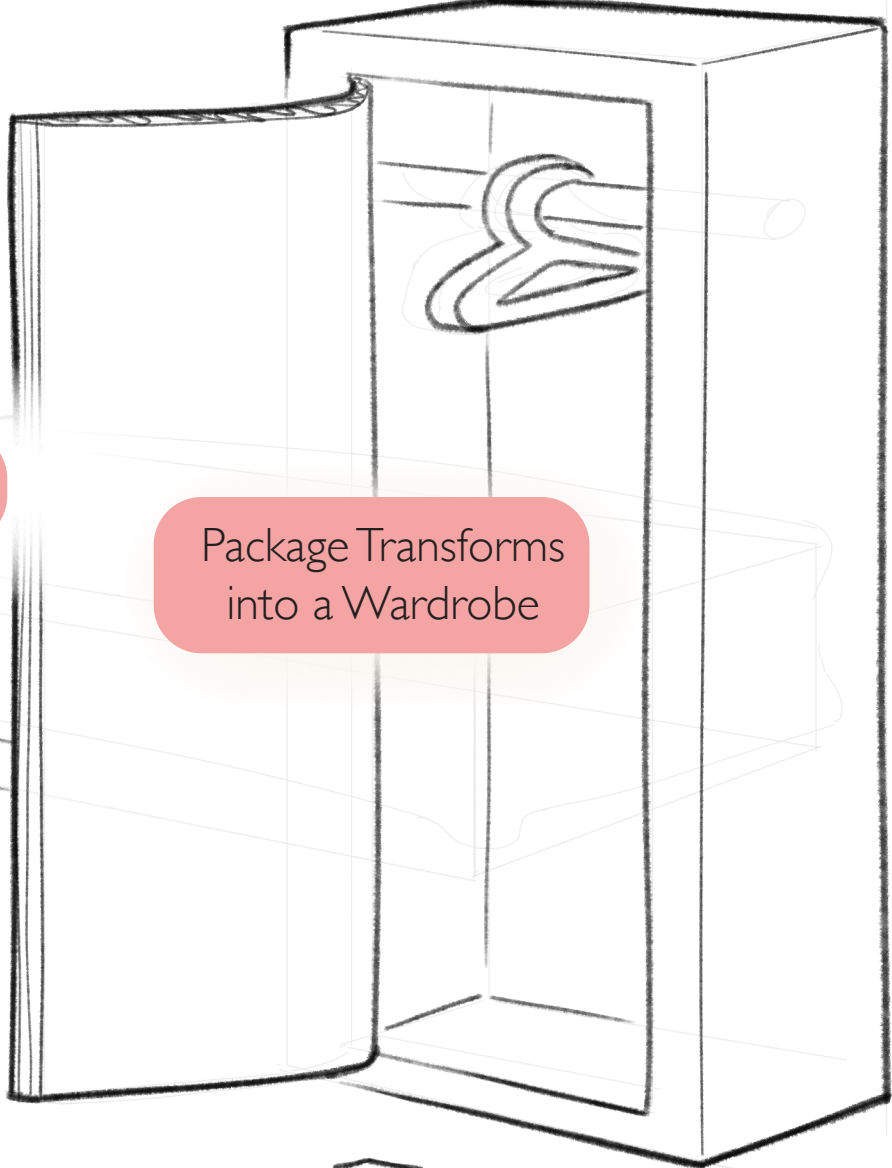

Wig



Pair of Shoes

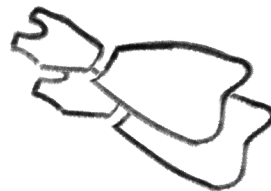

Dress Kit

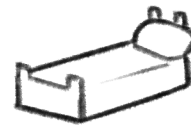

Bed

or

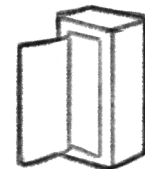

Wardrobe



# Options for Torso Attachment

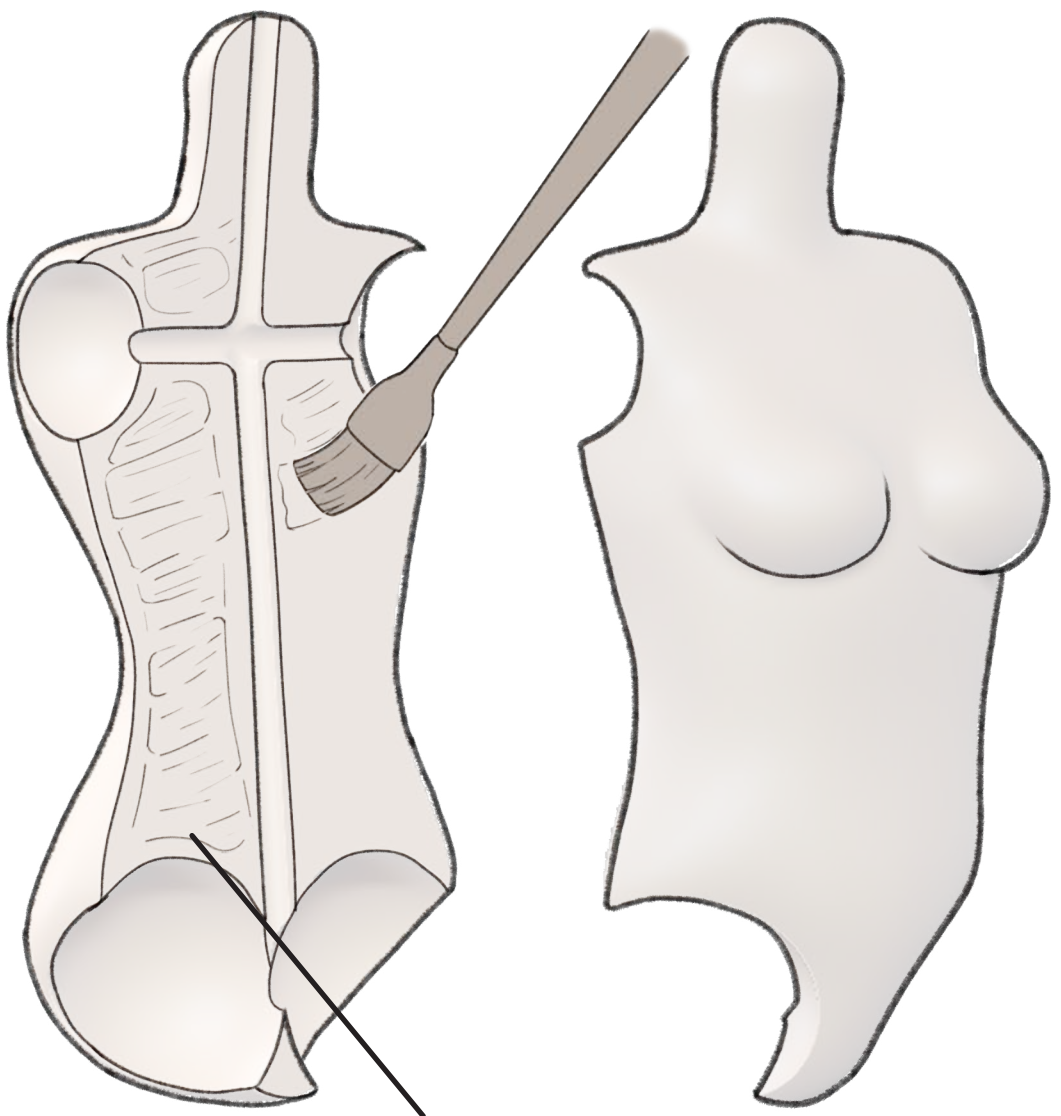

Hide Glue is Reversible with Water and Heat

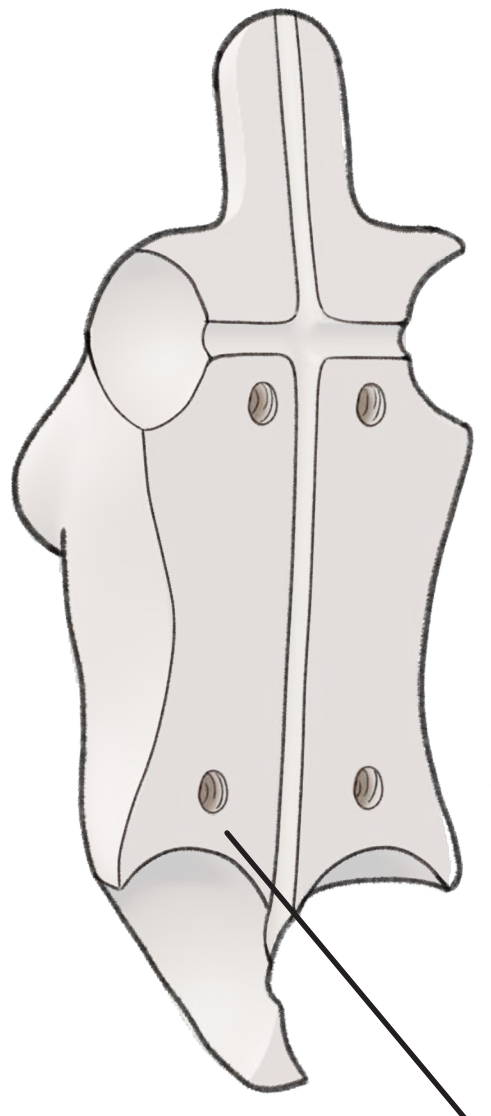

Held Together With Screws

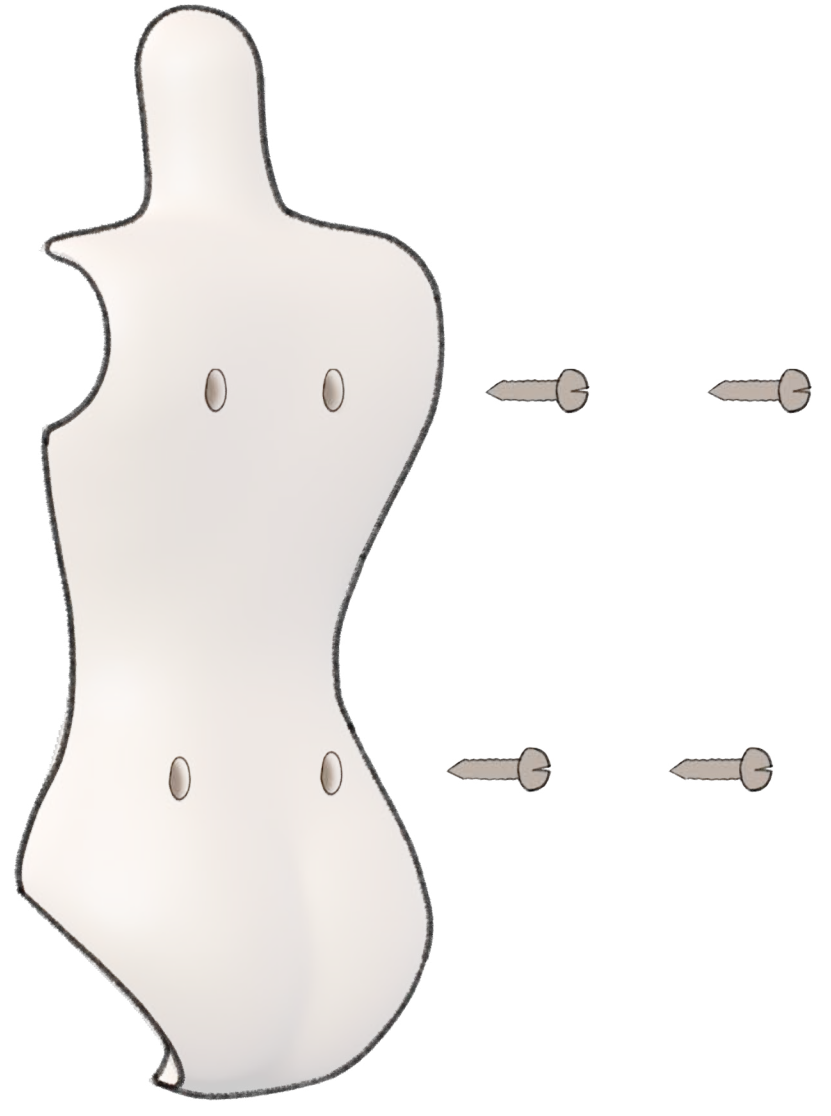

# Customize World With Sewing

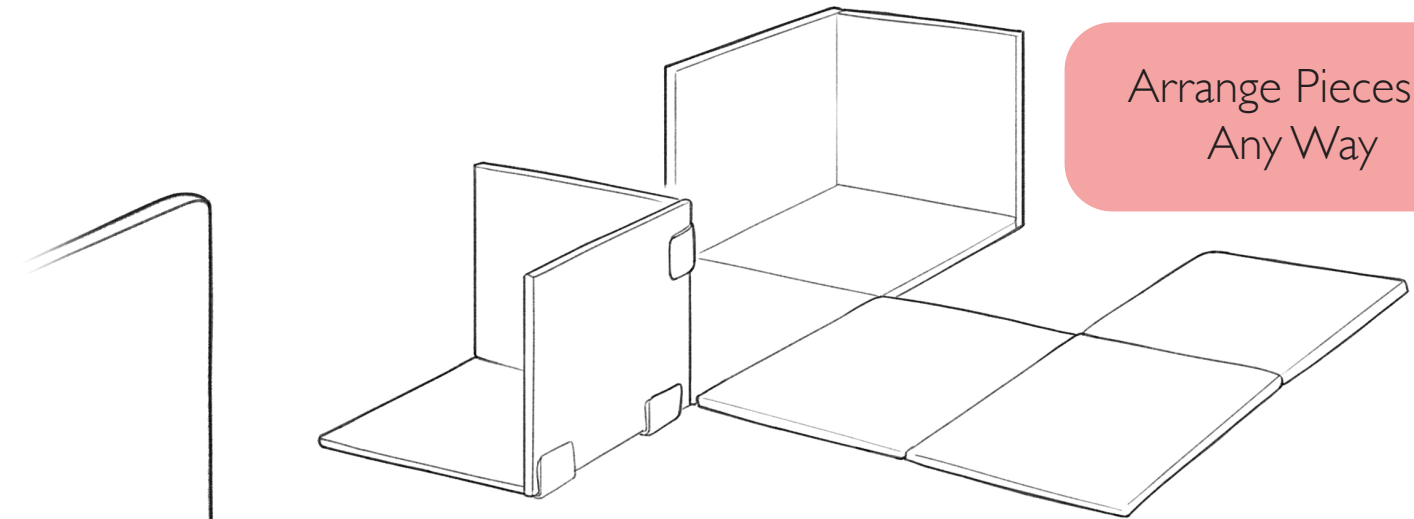

Arrange Pieces in Any Way



Sew on Felt Decorations

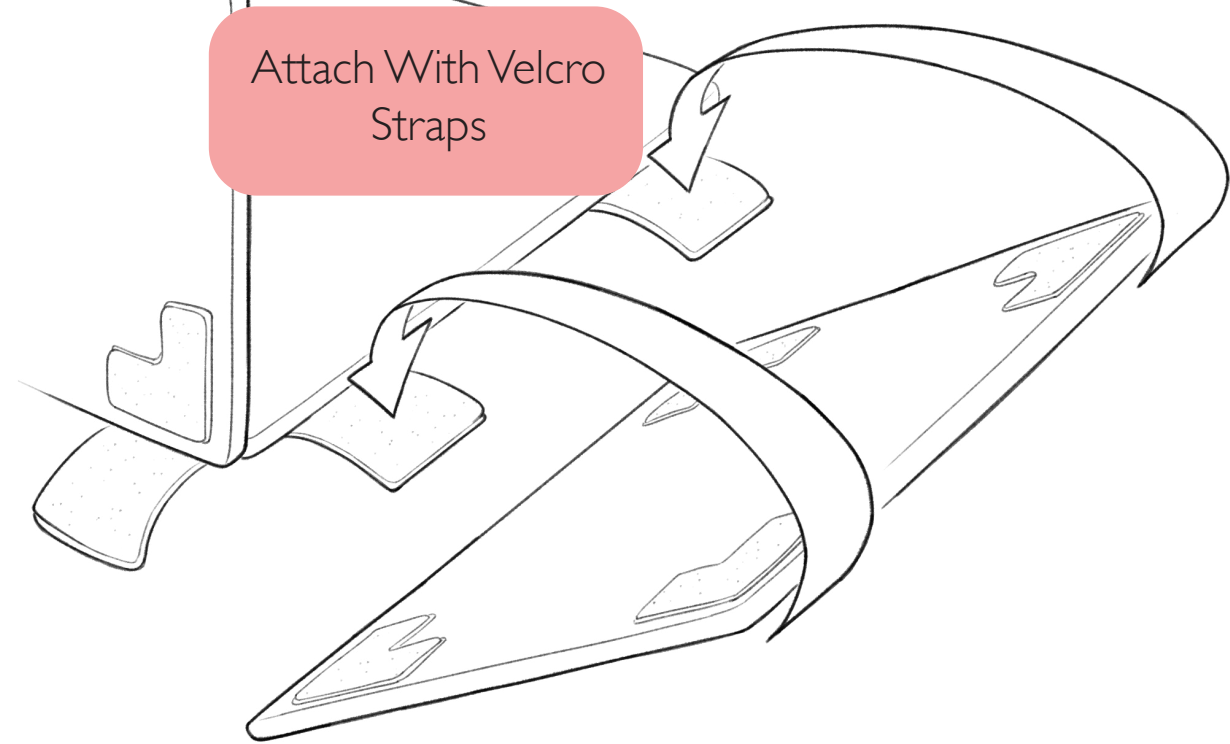

Attach With Velcro Straps

What the User Receives in Crafting Box

Thread Color Assortment

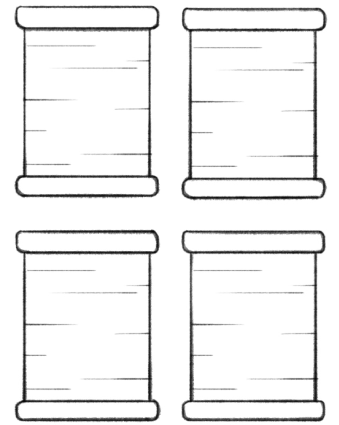

Pre-Cut Felt Pieces



Needle



16" x 16" Felt Base



# Doll House Doubles as Storage

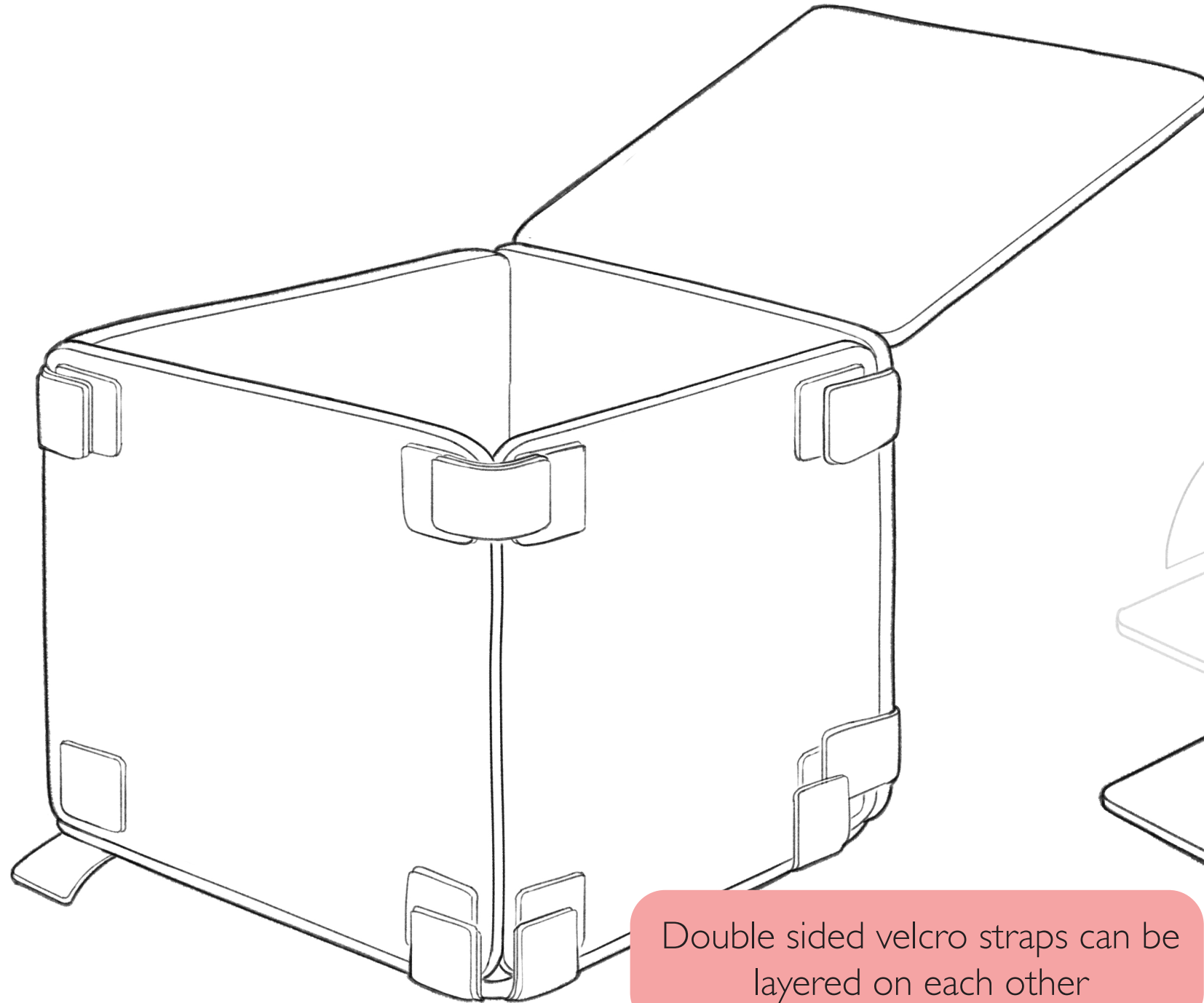

Double sided velcro straps can be layered on each other

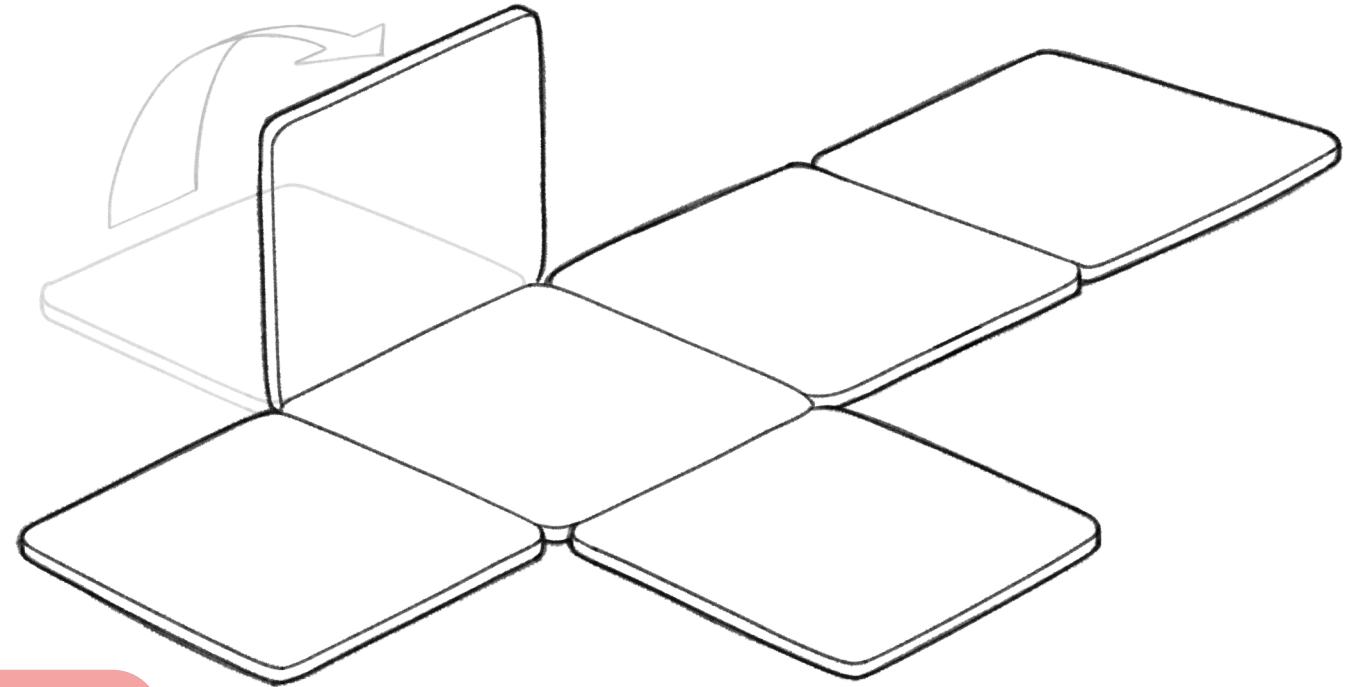

Double sided velcro straps can be layered on each other

# Customizable World

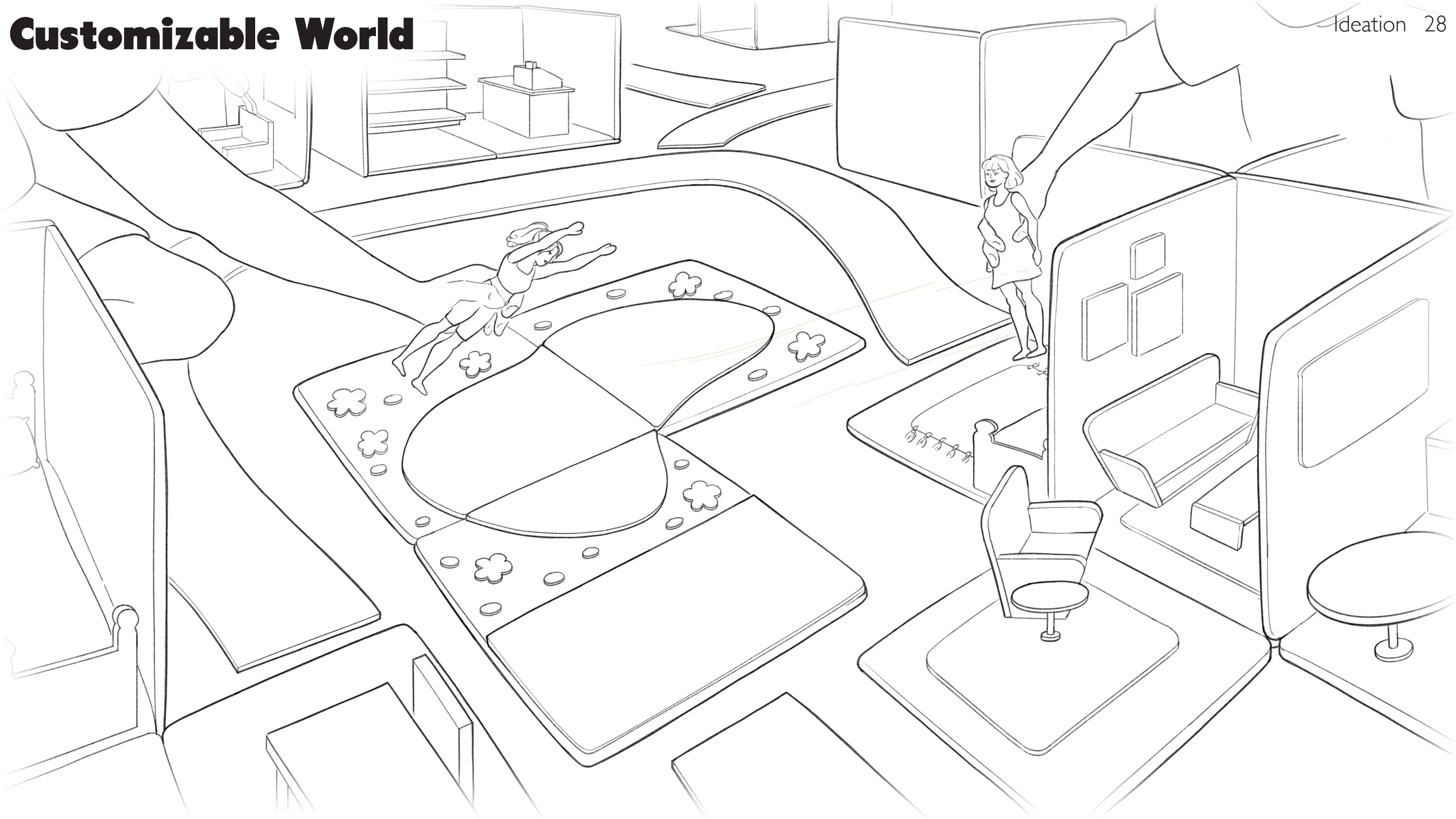

# Sewing Kit Options

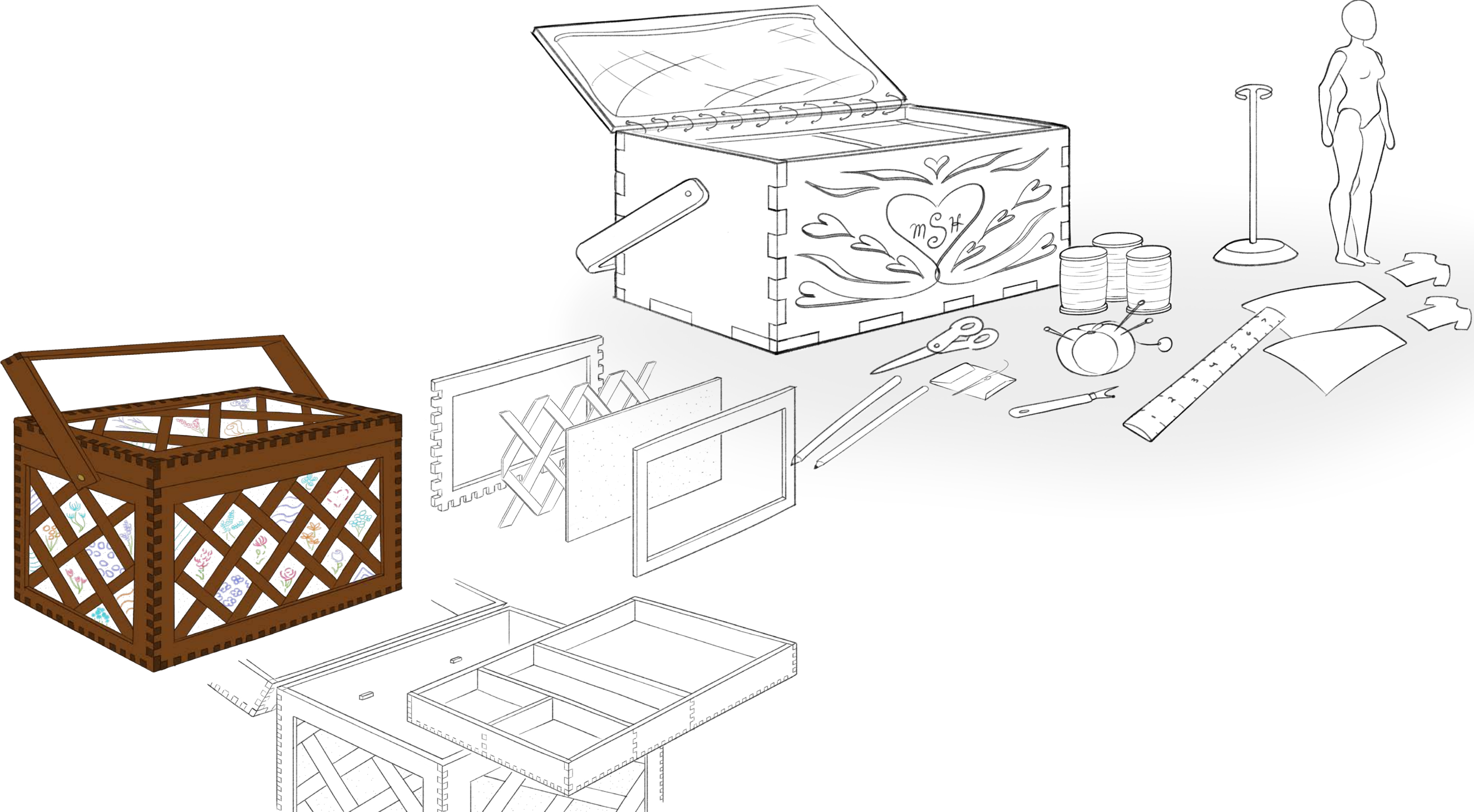

**Ren:**

Final Products

# Ren:

---

**A Premium, Sustainable Fashion Doll Kit That Teaches Children How To Sew!**



## **Renaissance Kids** **Learn Everything. Make Anything.**

### **Mission**

To teach practical, creative skills to children to apply for the rest of their lives.

### **Vision**

For Every child to be empowered to add to and modify their own world.



## Girls Age 8-12



### Crafty

Her favorite subject is art. She excels at alternative, creative project based learning.

### Some Experience

She has learned some hand sewing from her parent or grandparents. Wants to learn more!

### Aspirational

She has a million ideas of fashions for her doll, might need to pump the brakes with her skill level.

# Kids Can Sew?

Yes! In Montessori classes, children begin sewing with plastic needles and sewing cards in pre-school.

In 1st grade:

- Kids sew with sharp needles
- Cut fabric with craft scissors
- Try a task 3 times before asking for help
- Work independently from written instructions

## By learning sewing skills, kids also learn:

Persistence

Patience

Concentration

Independence

Trouble Shooting

Project Planning

Creativity

Starting Over

Empowerment

Curiosity

Problem Solving

Communication

## Look What They Are Capable of:



Sewing Buttons



“Inside Out” Sewing



Clean Stitches



# Why Sustainable Toys?

**90%** of all Toys are made of plastic

**80%** are landfilled or incinerated

Toys make up **6.0%** of landfill plastic

## Children form strong bonds with their favorite toys:

“I ran over his favorite airplane toy in the drive way, he was crying so much I immediately had to order a new one.”

“We bought two baby blankets when she was born, that way when one wore out years later we could replace it.”

What if we reduced plastic in toys by over half?



What if we could repair our favorite toys?



# First Purchase: Beginner Box

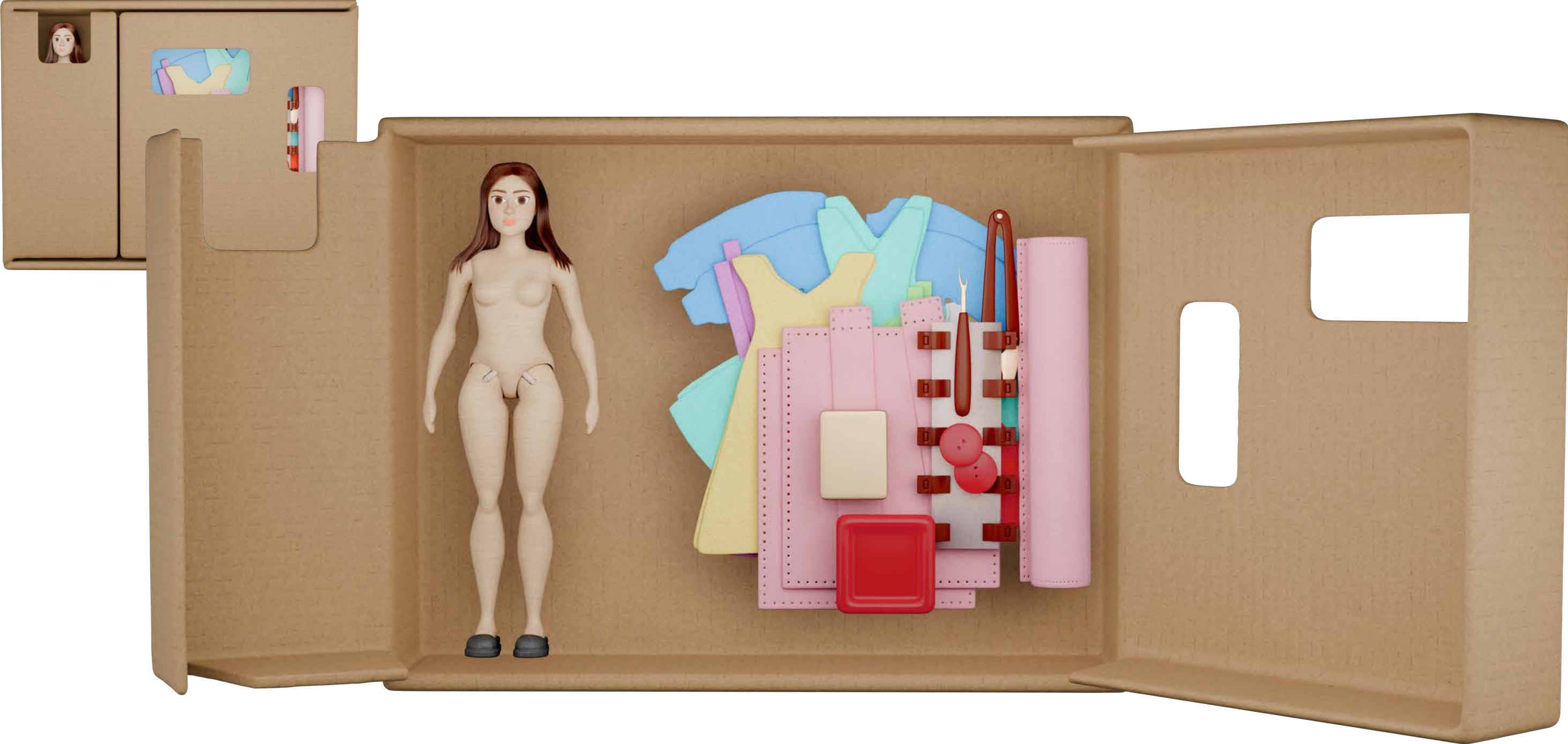

# Doll + Box Supplies + Outfits + Sewing Tools



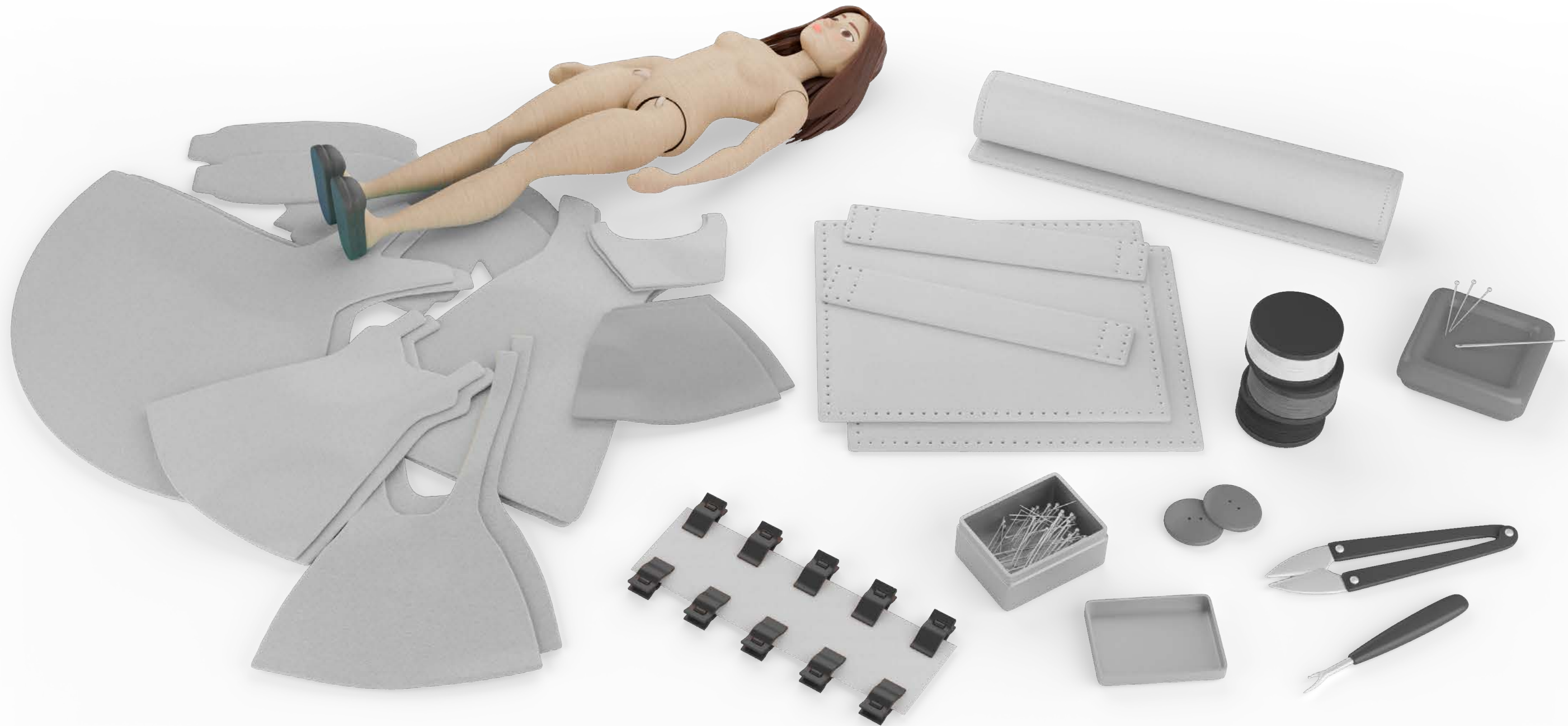

**Doll:** \_\_\_\_\_

# Fashion Doll: Realistic Styling

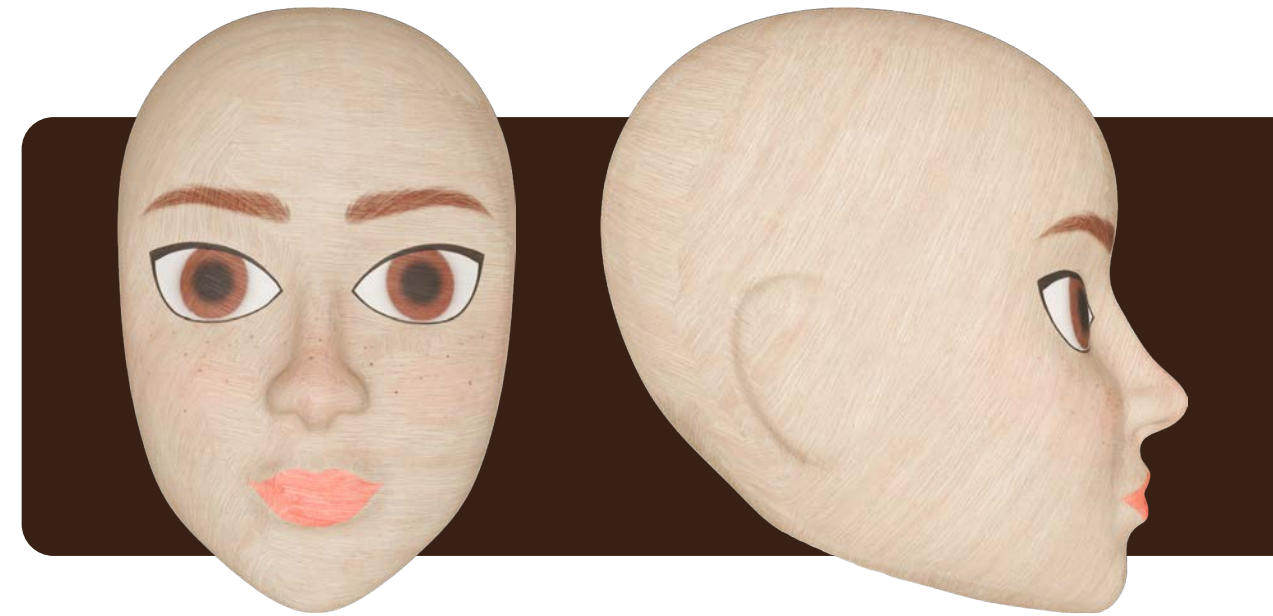
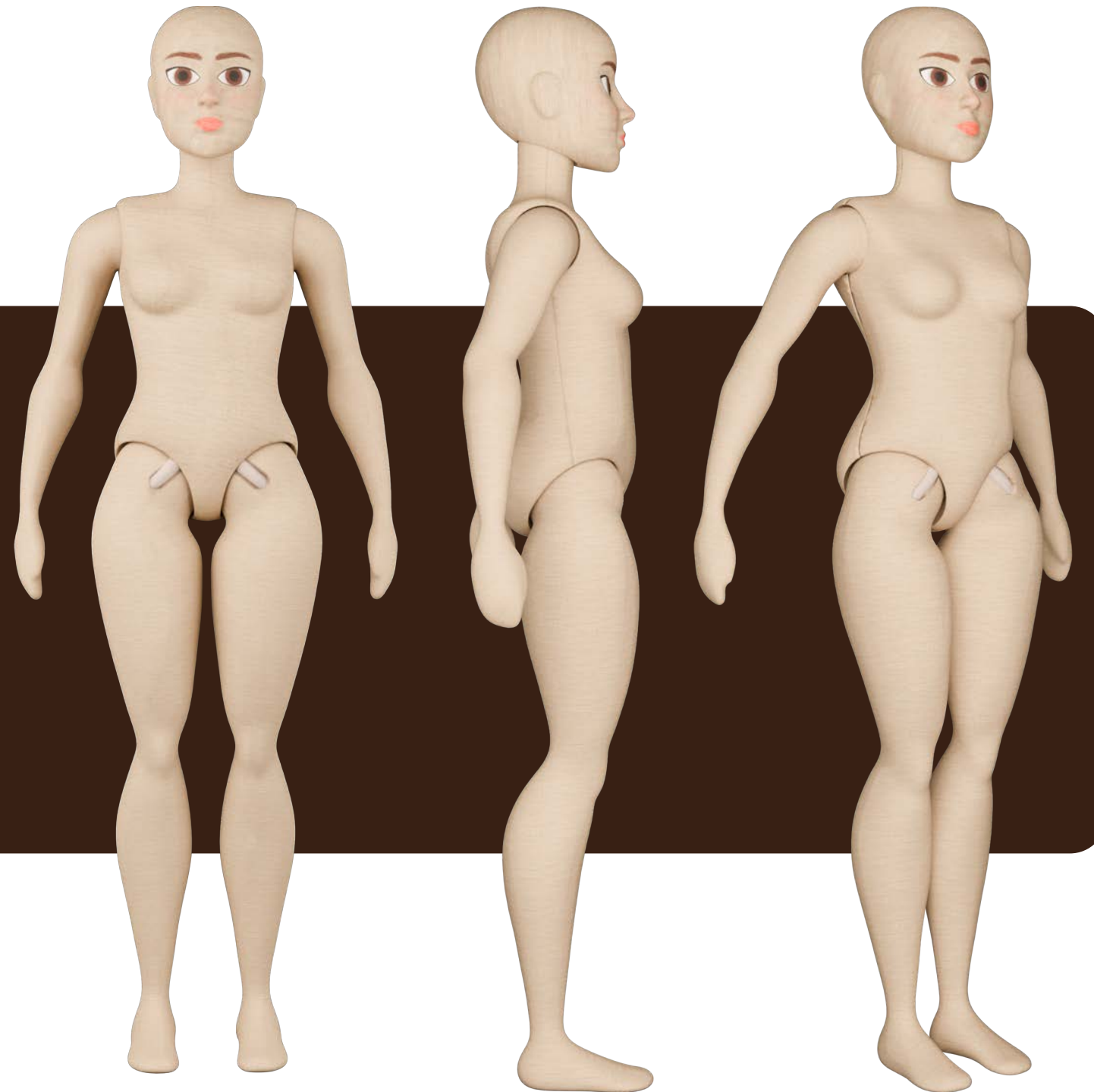

- Focus on a more realistic body type
- Doll is larger in the abdomen area like an adult
- A stronger body rather than a slimmer body
- Kids work with real proportion from the start

# Fashion Doll: String Jointing and Repairability

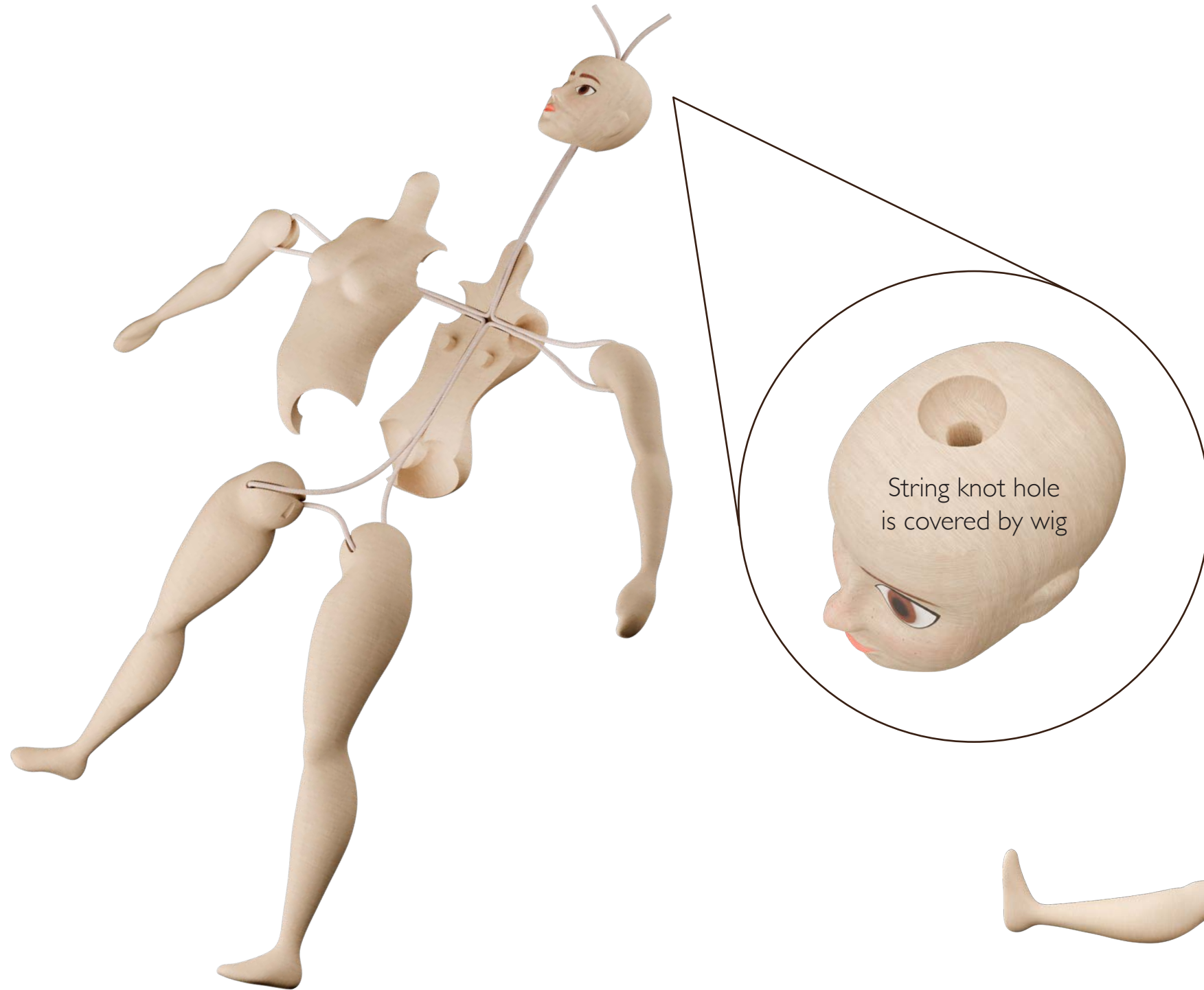

- If the string breaks: pop the torso pieces apart, replace the string, and reassemble the torso pieces
- the string jointing has a comparable amount of articulation compared to injection molded plastic
- the doll is prototyped from 3D Printed Wood

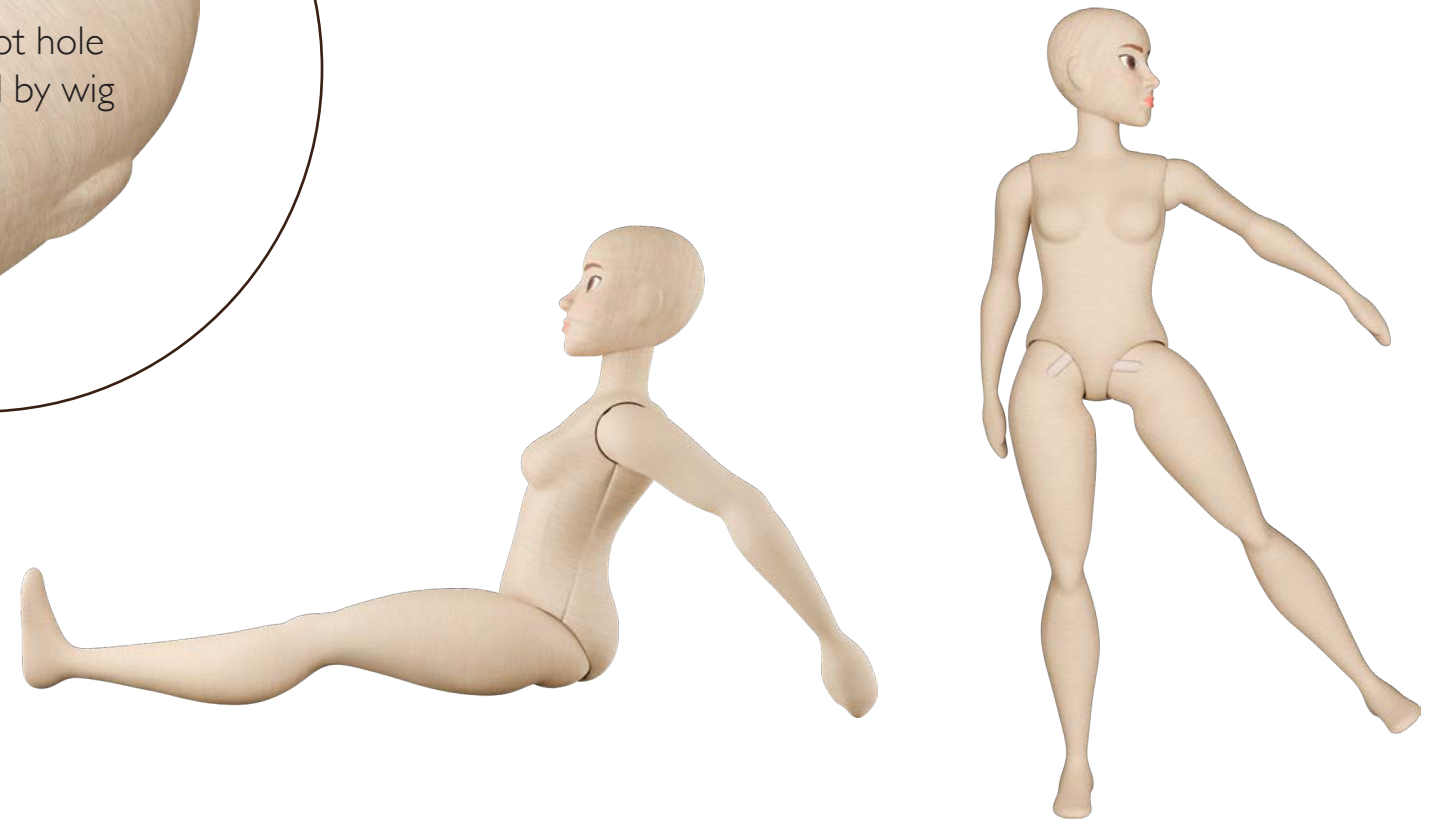





# Sewing Box: \_\_\_\_\_

# Sewing Kit: Design and Supplies

- The child receive felt pieces with pre-poked holes
- Because the child understand the construction of the box, they will be able to alter and repair the box
- If the child grows out of this box, it can still function as a storage for thread spools or other tools

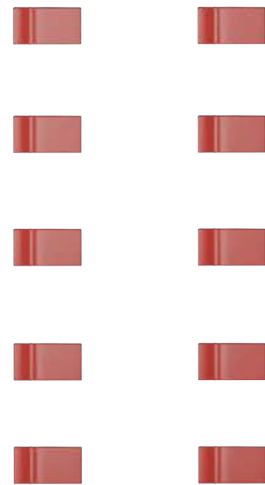
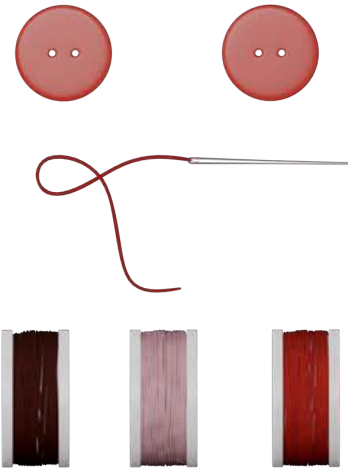

# Sewing Box: DIY



- The child learns basic hand stitches that they will use in their future fashion sewing like a back stitch or button sewing
- There are also pre poked holes for decorative sewing
- The 3mm felt creates a soft but sturdy sewing box

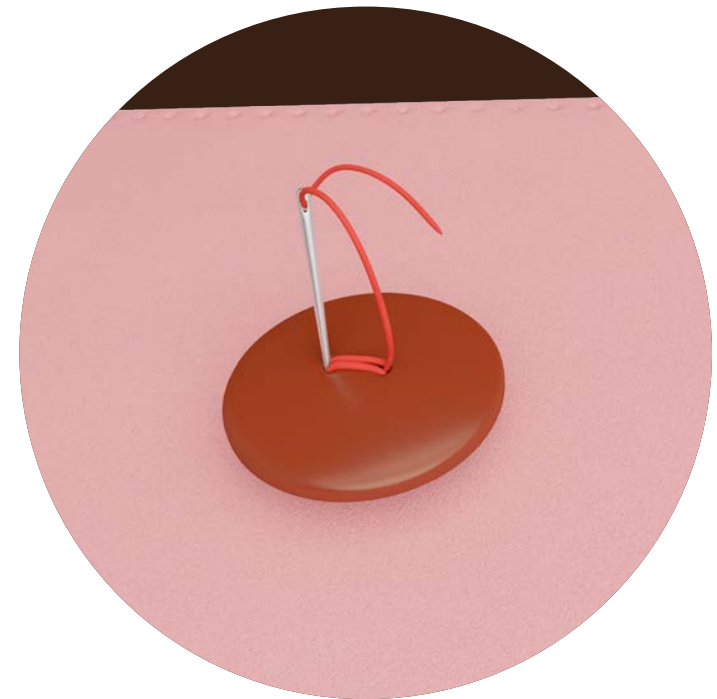
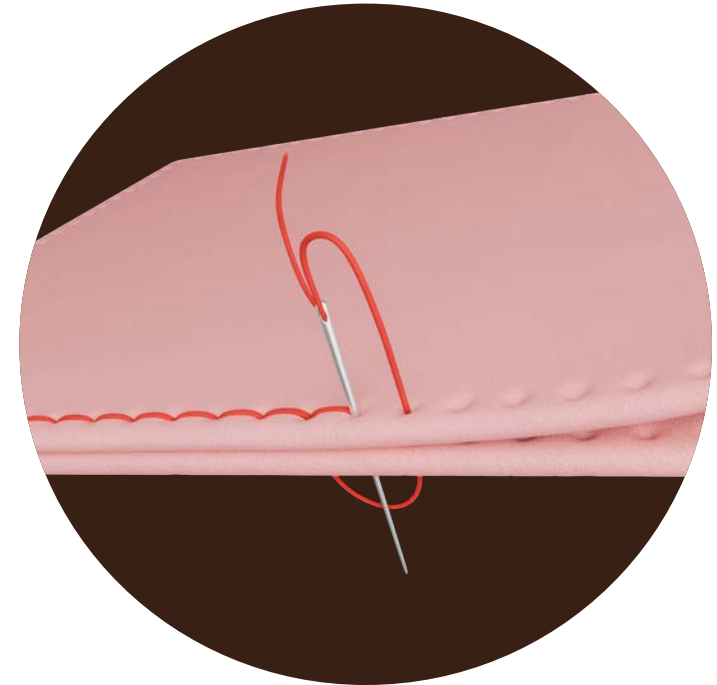

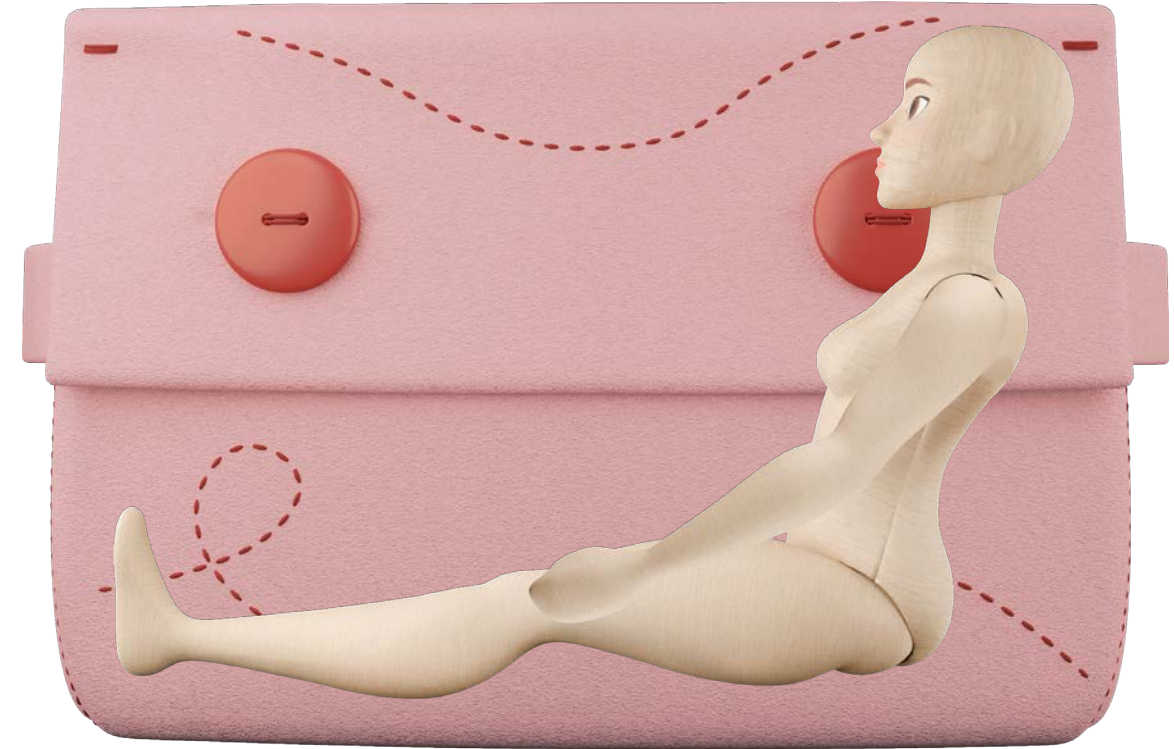

- The box is large enough to store the doll in a sitting position along with all the basic sewing supplies include in the beginner kit
- The box is also able to store a pair of fabric scissors at a diagonal





# Learning to Sew:

-----

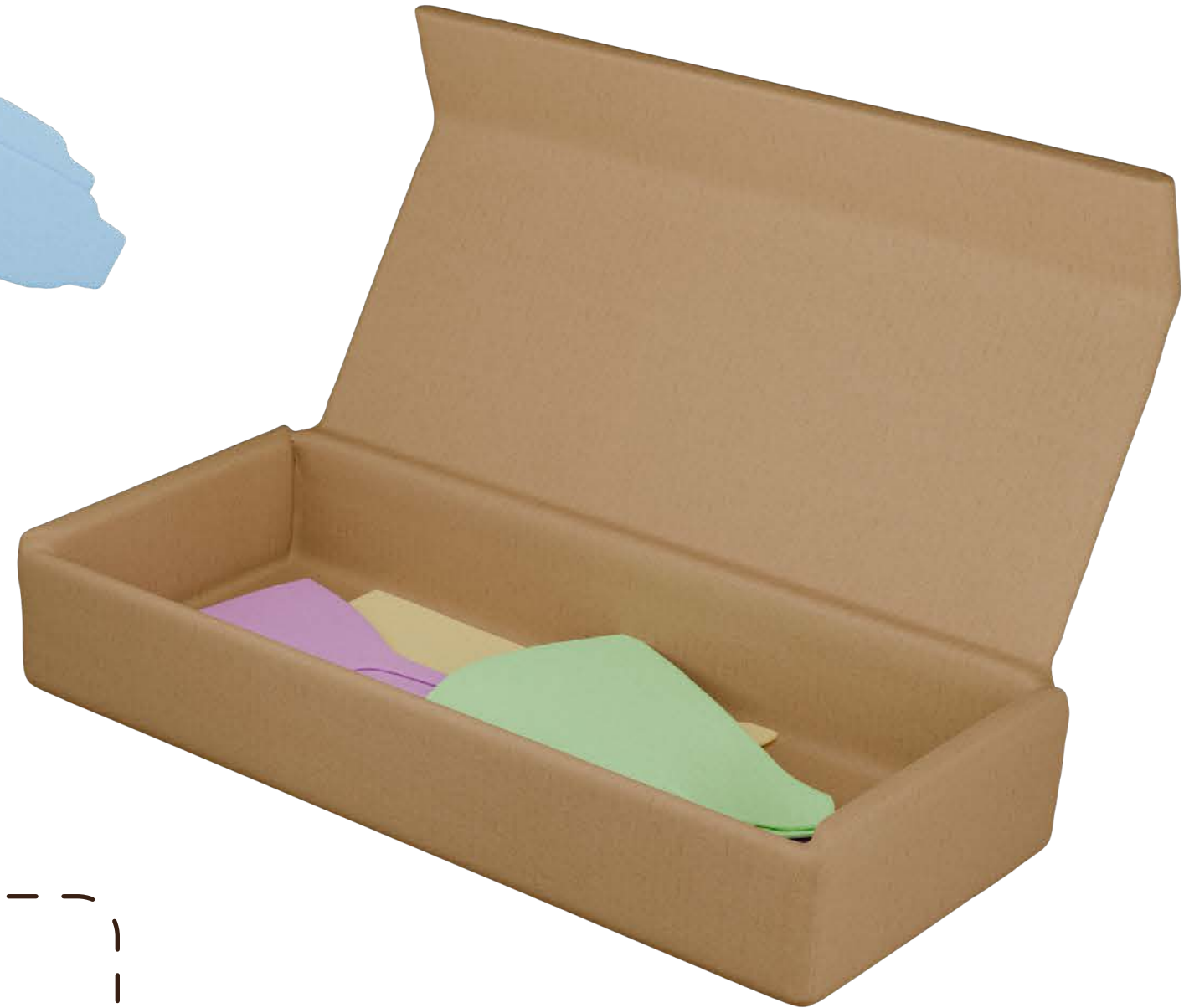

- Each fashion kits contains 5 outfits at a single sewing level
- Here is a level 1 kit, which includes pre-cut felt pieces
- There are 5 sewing levels, each with different levels of difficulty

# Learning to Sew: Levels

	<b>1</b>	<b>2</b>	<b>3</b>	<b>4</b>	<b>5</b>
<b>Materials</b>	Pre-Cut Felt Pieces	Pre-Cut T-Shirt Fabric	Paper Pattern + Fabric	Paper Pattern Only	Create Pattern + BYO Fabric
<b>Sewing Method</b>	Hand Sewing	Hand Sewing	Hand Sewing	Machine Sewing	Machine Sewing
<b>Fit</b>	Very Oversize, Simple Patterns	Oversized, Comfy Clothing	Good Fit w/ Closures	Best Fit w/ Closures	Design Own Fit
<b>Closures</b>	No Closures	Tie Closures	Velcro Closures	Snap Closures	Choose Own Closures
<b>Main Challenge</b>	Basic Hand Stitches	“Inside Out” Sewing + Hem	Finished Edges w/ Closures	Complex Pinning + Pressing	Decide Own Construction

# Learning to Sew: Levels

**1**

- Hand Sewing
- Pre-cut Felt
- Large sharp needle
- Contrast craft thread
- Garment Decoration



**2**

- Hand Sewing
- Pre-cut T-Shirt Fabric
- Simple Patterns
- Regular sewing needle
- Matching thread



**3**

- Hand Sewing
- Provided T-Shirt Fabric
- Paper Patterns
- Some Pattern Complexity



**4**

- Machine Sewing
- close to Lvl 3 patterns
- Paper patterns
- User chooses + provides own fabric



**5**

- Full independence
- Create own patterns in online design studio
- Print out own patterns
- Plan their own sewing





# Learn to Sew with Videos + Digital Instructions

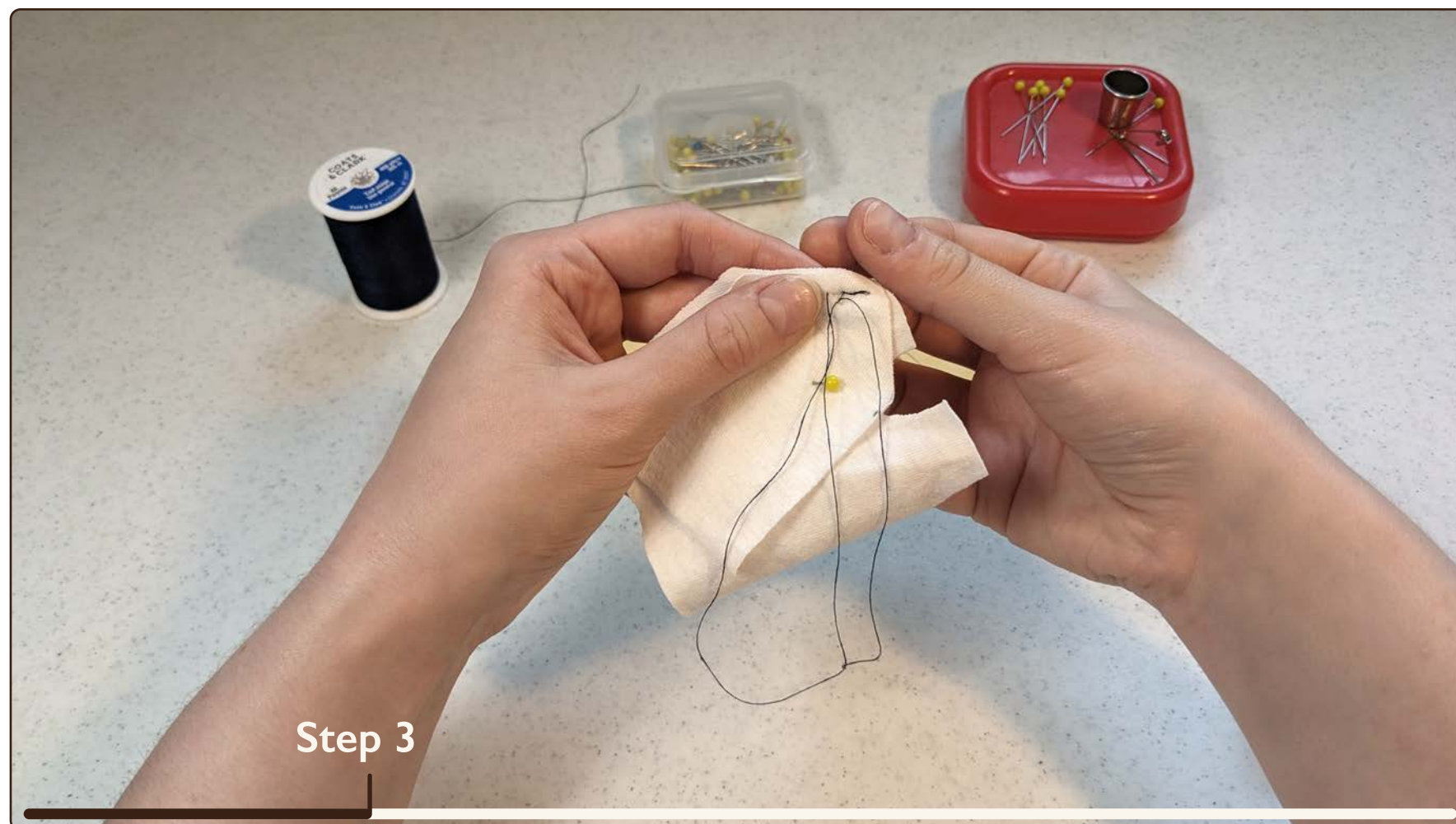

Step 3

## Level 4: Basic Short Sleeve T-Shirt

**STEP 3** Sew a backstitch. Repeat 3 more times for each arm hole seam

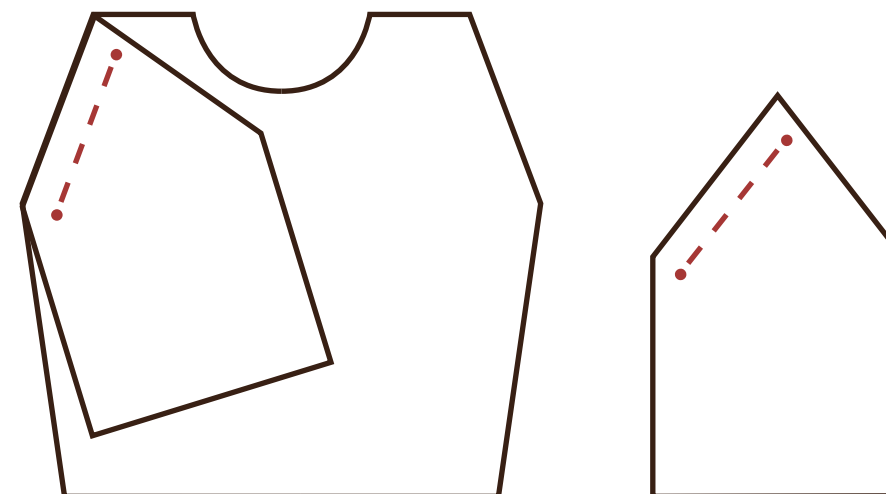

\* Right Sides Together \*

**STEP 4** Sew a backstitch along both shoulder seams.

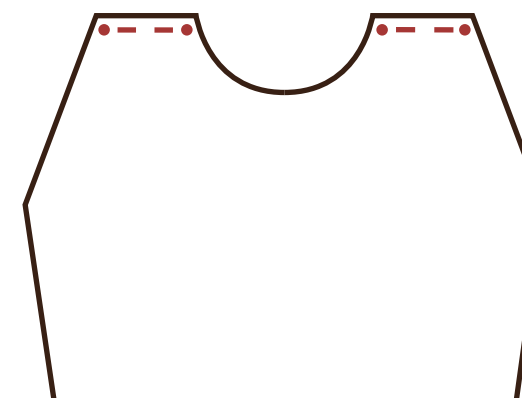

### Helpful Links

#### Steps:

1. Trace + Cut Pattern
2. Mark Shoulder Points
- 3. Sewing Arm Holes**
4. Sew Shoulder Seams

#### Tools Used:

- Basic Needle
- Matching Thread
- Pins
- Fabric Scissors

#### Foundations Tutorials:

- Back Stitch
- Level 3 Shirt
- Easy Collar
- Seams Allowances

# Ren:

---

**A Premium, Sustainable Fashion Doll Kit That Teaches Children How To Sew!**

